

Indexed
PubMed and
PubMed Central
ISI and JCR (Journal Citation Reports®)
included

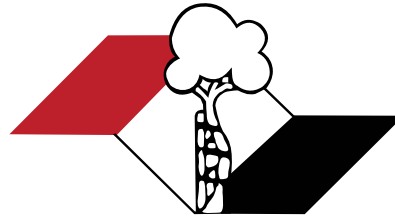

ISSN 1413-7852

Acta Ortopédica Brasileira

28 anos

Volume 28 – Number 2 – Year 2020

Acta Ortopédica Brasileira



Department of Orthopedics and Traumatology, Faculdade de Medicina da Universidade de São Paulo (DOT/FMUSP), São Paulo, SP, Brazil

Affiliated with Associação Brasileira de Editores Científicos



Indexed in PubMed, PubMed Central, Web of Science, JCR, Scopus Elsevier, SciELO, Redalyc (Red de Revistas Científicas de America Latina y el Caribe, España y Portugal), LILACS (Latin America Health Science Literature) and DOAJ (Directory of open access journals).



EDITORIAL TEAM

Editor-in-chief – Olavo Pires de Camargo

Department of Orthopedics and Traumatology, Faculdade de Medicina da Universidade de São Paulo (DOT/FMUSP), São Paulo, SP, Brazil

Editor Emeritus – Tarcísio Eloy Pessoa Barros Filho

Department of Orthopedics and Traumatology, Faculdade de Medicina da Universidade de São Paulo (DOT/FMUSP), São Paulo, SP, Brazil

Associate Editors

- Akira Ishida – Departamento de Ortopedia e Traumatologia da Universidade Federal de São Paulo, Unifesp, São Paulo, SP, Brasil • Alberto Cliquet Jr. – Departamento de Ortopedia e Traumatologia Faculdade de Ciências Médicas Universidade Estadual de Campinas – Unicamp, Campinas, SP, Brasil
- Arnaldo José Hernandez – Departamento de Ortopedia e Traumatologia da FMUSP, São Paulo, SP, Brasil • Claudio Santili – Departamento de Ortopedia e Traumatologia da Santa Casa de Misericórdia de São Paulo, São Paulo, SP, Brasil • Edison Noboru Fujiki – Faculdade de Medicina do ABC, SP, Brasil
- Everth Merida Herrera – Hospital de Ortopedia Magdalena de Las Salinas do Instituto Mexicano de Seguro Social – Cuauhtémoc, Mexico • Flávio Faloppa – Departamento de Ortopedia e Traumatologia da Universidade Federal de São Paulo, Unifesp, São Paulo, SP, Brasil • Gustavo Molina – Departamento de Ortopedia e Traumatologia, Medellín, Colombia • Jack Zigler – Texas Back Institute, Texas, Estados Unidos • Jesse B. Júpiter – Hospital Geral de Massachusetts Harvard – Boston, EUA • José Batista Volpon – Departamento de Biomecânica, Medicina e Reabilitação do Aparelho Locomotor (RAL), Faculdade de Medicina de Ribeirão Preto, FMRP-USP, Ribeirão Preto, SP, Brasil • Lawrence Menendez – USC-Keck School of Medicine, Los Angeles, Estados Unidos • Luís Aponte – Hospital Italiano de Buenos Aires, Buenos Aires, Argentina • Luiz Eugenio Garcez Leme – Departamento de Ortopedia e Traumatologia da FMUSP
- Mark Vrahas – Departamento de Ortopedia do Hospital Geral de Massachusetts – Boston, EUA • Moises Cohen – Departamento de Ortopedia e Traumatologia da Universidade Federal de São Paulo – Unifesp, São Paulo, SP, Brasil • Osmar Avanzi – Departamento de Ortopedia e Traumatologia da Santa Casa de Misericórdia de São Paulo, São Paulo, SP, Brasil • Philippe Hernigou – Universidade de Paris-Leste – Paris, France • Pierre J. Hoffmeyer – Universidade de Genève – Genebra, Suíça • Rami Mosheiff – Diretor da Unidade de Trauma Ortopédico da Universidade Hadassah Medical Center, Jerusalem, Israel • Ricardo Pietrobon – Departamento de Cirurgia da Duke University Medical Center, Darhan, Estados Unidos • Wade Smith – University of Texas, Denver, Estados Unidos.

Editorial Board

- Alberto Tesconi Croci – Departamento de Ortopedia e Traumatologia da FMUSP, São Paulo, SP, Brasil;
- André Mathias Baptista – Instituto de Ortopedia e Traumatologia do Hospital das Clínicas da FMUSP, São Paulo, SP, Brasil;
- André Pedrinelli – Instituto de Ortopedia e Traumatologia do Hospital das Clínicas da FMUSP, São Paulo, SP, Brasil;
- Antonio Carlos Fernandes – AACD – Associação de Assistência à Crianças Deficientes, São Paulo, SP, Brasil;
- Caio Augusto de Souza Nery – Departamento de Ortopedia e Traumatologia da Universidade Federal de São Paulo, Unifesp, São Paulo, SP, Brasil;
- Carlo Milani – Departamento de Ortopedia e Traumatologia da Faculdade de Medicina do ABC, Santo André, SP, Brasil;
- Carlos Roberto Schwartzmann – Universidade Federal de Ciências da Saúde de Porto Alegre, Porto Alegre, RS, Brasil;
- Celso Herminio Ferraz Picado – Universidade de São Paulo, Ribeirão Preto, SP, Brasil;
- Cláudio Henrique Barbieri – Departamento de Biomecânica, Medicina e Reabilitação do Aparelho Locomotor – Laboratório Bioengenharia – Faculdade de Medicina de Ribeirão Preto, FMRP-USP, São Paulo, SP, Brasil;
- Edgard dos Santos Pereira – Universidade de Santo Amaro, São Paulo, SP, Brasil;
- Edie Benedito Caetano – Departamento de Ortopedia e Traumatologia Faculdade de Medicina de Sorocaba – PUC, Sorocaba, SP, Brasil;
- Eduardo Barros Puertas – Departamento de Ortopedia e Traumatologia da Universidade Federal de São Paulo, Unifesp, São Paulo, SP, Brasil;
- Fabio Janson Angelini – Instituto de Ortopedia e Traumatologia do Hospital das Clínicas da FMUSP, São Paulo, SP, Brasil;
- Fernando Antonio Mendes Façanha Filho – Departamento de Ortopedia do Instituto Dr. José Frola, Fortaleza, CE, Brasil;
- Fernando Baldy dos Reis – Departamento de Ortopedia e Traumatologia da Universidade Federal de São Paulo – Unifesp, São Paulo, SP, Brasil;
- Geraldo Rocha Motta Filho – Instituto Nacional de Traumatologia e Ortopedia – INTO-MS, Rio de Janeiro, RJ, Brasil;
- Gilberto Luis Camanho – Departamento de Ortopedia e Traumatologia da FMUSP, São Paulo, SP, Brasil;
- Gildásio de Cerqueira Daltro – Universidade Federal da Bahia, Salvador, BA, Brasil;
- Glaydson Godinho – Hospital Belo Horizonte, Belo Horizonte, MG, Brasil;
- Hamilton da Rosa Pereira – Universidade Estadual Paulista Júlio de Mesquita Filho, Botucatu, SP, Brasil;
- Helio Jorge Alvachian Fernandes – Departamento de Ortopedia e Traumatologia da Universidade Federal de São Paulo – Unifesp, São Paulo, SP, Brasil;
- Helton Luiz Aparecido Defino – Departamento de Biomecânica, Medicina e Reabilitação do Aparelho Locomotor (RAL), Faculdade de Medicina de Ribeirão Preto, FMRP-USP, Ribeirão Preto, SP, Brasil;
- Isanio Vasconcelos Mesquita – Universidade Estadual do Piauí, Teresina, PI, Brasil;
- João Mauricio Barreto – Departamento de Ortopedia e Traumatologia, Santa Casa de Misericórdia do Rio de Janeiro, Rio de Janeiro, RJ, Brasil;
- Jorge dos Santos Silva – Instituto de Ortopedia e Traumatologia do Hospital das Clínicas da FMUSP, São Paulo, SP, Brasil;
- José Antonio Pinto – Departamento de Ortopedia e Traumatologia da Universidade Federal de São Paulo – Unifesp, São Paulo, SP, Brasil;
- José Sérgio Franco – Faculdade de Medicina da Universidade Federal do Rio de Janeiro, Rio de Janeiro, RJ, Brasil;
- Kodí Edson Kojima – Instituto de Ortopedia e Traumatologia do Hospital das Clínicas da FMUSP, São Paulo, SP, Brasil;
- Luiz Antonio Munhoz da Cunha – Universidade Federal do Paraná, Santa Catarina, PR, Brasil;
- Luiz Aurelio Mestriner – Departamento de Ortopedia e Traumatologia da Universidade Federal de São Paulo – Unifesp, São Paulo, SP, Brasil;
- Luiz Roberto Gomes Vialle – Universidade Católica do Paraná, Curitiba, Santa Catarina, PR, Brasil;
- Marcelo Tomanik Mercadante – Departamento de Ortopedia e Traumatologia da Santa Casa de Misericórdia de São Paulo, São Paulo, SP, Brasil;
- Marco Antonio Percope de Andrade – Departamento de Aparelho Locomotor da Faculdade de Medicina, Universidade Federal de Minas Gerais, Belo Horizonte, MG, Brasil;
- Marcos Antonio Almeida Matos – Escola Baiana de Medicina e Saúde Pública, Salvador, BA, Brasil;
- Mateus Saito – Instituto de Ortopedia e Traumatologia do Hospital das Clínicas da FMUSP, São Paulo, SP, Brasil;
- Maurício Etchebehere – Departamento de Ortopedia e Traumatologia da Faculdade de Ciências Médicas da Universidade Estadual de Campinas (Unicamp), Campinas, SP, Brasil;
- Miguel Angel Curiel Torres – Instituto Mexicano del Seguro Social, Coyoacán, México;
- Nilton Mazzer – Departamento de Biomecânica, Medicina e Reabilitação do Aparelho Locomotor – Hospital das Clínicas – Faculdade de Medicina de Ribeirão Preto – FMRP-USP, São Paulo, SP, Brasil;
- Osmar Pedro Arbix Camargo – Faculdade de Ciências Médicas da Santa de Misericórdia, São Paulo, SP, Brasil;
- Osvandré Luiz Canfield Lech – Instituto de Ortopedia e Traumatologia de Passo Fundo, RS, Brasil;
- Patricia M. de Moraes Barros Fucs – Departamento de Ortopedia e Traumatologia da Santa Casa de Misericórdia de São Paulo, São Paulo, SP, Brasil;
- Paulo César Schott – Universidade Federal Fluminense, Rio de Janeiro, RJ, Brasil;
- Pedro Péricles Ribeiro Baptista – Departamento de Ortopedia e Traumatologia da Santa Casa de Misericórdia de São Paulo, São Paulo, SP, Brasil;
- Paulo César Schott – Universidade Federal Fluminense, Rio de Janeiro, RJ, Brasil;
- Pedro Péricles Ribeiro Baptista – Departamento de Ortopedia e Traumatologia da Santa Casa de Misericórdia de São Paulo, São Paulo, SP, Brasil;
- Rames Mattar Junior – Departamento de Ortopedia e Traumatologia da FMUSP, São Paulo, SP, Brasil;
- Renato Graça – Universidade Federal Fluminense, Rio de Janeiro, RJ, Brasil;
- Reynaldo Jesus Garcia Filho – Departamento de Ortopedia e Traumatologia da Universidade Federal de São Paulo, Unifesp – São Paulo, SP, Brasil;
- Roberto Sergio de Tavares Canto – Centro Universitário do Triângulo, Uberlândia, MG, Brasil;
- Rosalvo Zósimo Bispo Júnior – Universidade Federal da Paraíba (UFPB), João Pessoa, PB, Brasil;
- Sérgio Afonso Hennemann – Instituto de Traumatologia e Ortopedia do Hospital Mãe de Deus, Porto Alegre, RS, Brasil;
- Sergio Eduardo Vianna – Instituto Nacional de Traumatologia e Ortopedia, INTO, Rio de Janeiro, RJ, Brasil;
- Sérgio Luiz Checchia – Departamento de Ortopedia e Traumatologia da Santa Casa de Misericórdia de São Paulo, São Paulo, SP, Brasil;
- Sérgio Zylbersztejn – Universidade Federal de Ciências da Saúde de Porto Alegre, Porto Alegre, RS, Brasil;
- Túlio Diniz Fernandes – Departamento de Ortopedia e Traumatologia da FMUSP, São Paulo, SP, Brasil;
- Walter Manna Albertoni – Departamento de Ortopedia e Traumatologia da Universidade Federal de São Paulo – Unifesp, São Paulo, SP, Brasil;
- William Dias Belangero – Universidade Estadual de Campinas – Unicamp, Campinas, SP, Brasil.

Advisory Editor – Arthur Tadeu de Assis

Executive Editor – Ana Carolina de Assis

Administrative Editor – Atha Comunicação Editora

Logo creation – Caio Augusto de Souza Nery

ACTA ORTOPÉDICA BRASILEIRA

INSTRUCTIONS TO AUTHORS

(Reviewed January 2016)

The journal *Acta Ortopédica Brasileira*, official organ of the Department of Orthopedics and Traumatology, Faculdade de Medicina da Universidade de São Paulo (DOT/FMUSP), is published bimonthly in six issues per year (jan/feb, mar/apr, may/jun, jul/aug, sep/oct, and nov/dec) with English version. The titles, abstracts and keywords are published in English and Portuguese. The publication follows entirely the international standard of the International Committee of Medical Journal Editors (ICMJE) - Vancouver Convention - and its uniform requirements [http://www.icmje.org/]. Submitted papers are sent for double-blind peer review evaluation to decide whether they should be published or not, suggesting improvements, asking the authors for clarification and making recommendations to the Editor-in-Chief. The concepts and statements contained in the papers are the sole responsibility of the authors. We ask authors to observe the following instructions for publication.

ARTICLES FORMAT

NUMBER OF WORDS RECOMMENDED ACCORDING TO THE PUBLICATION TYPE: The criteria specified below should be observed for each type of publication. The electronic counting of words should start at the Introduction and end at the Conclusion.

Recommendations for articles submitted to *Acta Ortopédica Brasileira*

Type of Article	Abstract	Number of words	References	Figures	Tables	Maximum number of authors allowed
Original	Structured, up to 200 words	2,500 Excluding abstract, references, tables and figures	20	10	6	6
Update / Review*	Non-structured, up to 200 words	4,000 Excluding abstract, references, tables and figures	60	3	2	2
Editorial*	No abstract	500	0	0	0	1

*These contributions shall be published at the Editors' criteria, with due replica, when applicable.

MANUSCRIPT PREPARATION: The journal *Acta Ortopédica Brasileira* receives the following types of contributions: Original Article, Update Article and Review Article. The Update and Review articles are only considered by invitation from the Editorial Board.

Manuscripts should be sent in .txt or .doc files, double-spaced, with wide margins. Measures should be expressed in the International System (*Système International*, SI), available at <http://physics.nist.gov/cuu/Units> and standard units, where applicable.

It is recommended that authors do not use abbreviations in the title and limit their use in the abstract and in the text.

The generic names should be used for all drugs. The drugs can be referred to by their trade name, however, the manufacturer's name, city and country or electronic address should be stated in brackets in the Materials and Methods section.

ABBREVIATIONS: The use of abbreviations should be minimized. Abbreviations should be defined at the time of its first appearance in the abstract and also in the text. Non-standard abbreviations shall not be used, unless they appear at least three times in the text.

Measurement units (3 ml or 3 mL, but not 3 milliliters) or standard scientific symbols (chemical elements, for example, Na and not sodium) are not considered abbreviations and, therefore, should not be defined. Authors should abbreviate long names of chemical substances and therapeutic combinations terms. Abbreviations in figures and tables can be used for space reasons, but should be defined in the legend, even if they were defined in the article.

PRESENTATION LETTER: The cover letter accompanying the submission of the manuscript should be signed by the corresponding author and should include the following information: Title, names of all authors, text authorizing the publication of the article, stating that it has not been submitted simultaneously elsewhere and it has not been previously published (publication in another language is considered as the same article). Authors should make sure that the manuscript is entirely in accordance with the instructions.

CLINICAL TRIALS: The journal *Acta Ortopédica Brasileira* supports the Clinical Trials Registry policy of the World Health Organization (WHO) and the ICMJE, recognizing the importance of these initiatives for the registration and international dissemination of clinical studies in open access. Therefore, it will only accept for publication articles involving clinical research that have received an identification number in one of the clinical trials registry platforms validated by WHO and ICMJE. The URLs of these registry platforms are available at the ICMJE page [http://www.icmje.org/about-icmje/faqs/clinical-trials-registration/].

CONFLICT OF INTERESTS: As recommended by the ICMJE and resolution of the Brazilian Federal Council of Medicine nº 1595/2000, authors have the responsibility to recognize and declare any potential financial conflicts of interest, as well as conflicts of other nature (commercial, personal, political, etc.) involved in developing the work submitted for publication.

ACKNOWLEDGEMENTS: Authors can acknowledge financial support to the work in the form of research grants, scholarships and other, as well as professionals who do not qualify as co-authors of the article, but somehow contributed to its development.

CORRECTION OF GALLEY PROOFS: As soon as they are ready, the galley proofs in electronic form will be sent by e-mail to the corresponding author. Authors should return proofs, also by e-mail, with the necessary corrections within 48 hours maximum after its receipt. This aims to expedite the review process and publication of the article.

COPYRIGHT: All statements published in the articles are the authors' responsibility. However, all published material becomes the property of the publisher, which shall reserve the copyright. Therefore, no material published in *Acta Ortopédica Brasileira* can be marketed without the written permission of the publisher. All authors of articles submitted to *Acta* must sign a Copyright Transfer Agreement, which will take effect from the date of acceptance of the paper.

ORGANIZING THE ELECTRONIC FILE: All parts of the manuscript should be included in a single file. It should be formed by the cover page, then the text, references, figures (with their captions) and finally, tables and charts (with their respective captions).

COVERPAGE: The title page should contain:

- The article category (original article, review article or update article);
- The full title in Portuguese and English with up to 80 characters. The title should be concise, but informative;
- The full name of each author (without abbreviations); and their institutional affiliations (the units should be presented in ascending order of hierarchy, e.g. department, faculty/institution, university). The names of institutions and programs should be submitted preferably in full and in the original language of the institution or in the English version when writing is not Latin (e.g. arabic, mandarin, greek);

d) The place where the work was performed;

e) Name, address, telephone number and e-mail of the corresponding author.

ABSTRACT: The abstract in Portuguese and in English should be structured in cases of original articles and shall present the study's objectives clearly, methods, results and main conclusions and should not exceed 200 words (do not include any reference citations). Moreover, the abstract should include the level of evidence and the type of study, according to the classification table attached at the end of this text.

KEYWORDS: The article should include at least three and at most six descriptors in Portuguese and in English, based on the Descriptors of Health Sciences (DeCS) <http://decs.bvs.br/> or Medical Subject Headings (MeSH) of the National Library of Medicine, available at <http://www.nlm.nih.gov/mesh/meshhome.html>

INTRODUCTION: The introduction of the article shall present the matter and purpose of the study, including citations without, however, making an extensive review of the matter.

MATERIALS AND METHODS: This section should describe the experiments (quantitatively and qualitatively) and procedures in sufficient detail to allow other researchers to reproduce the results or provide continuity to the study.

When reporting experiments on humans or animals, authors should indicate whether the procedures followed the rules of the Ethics Committee on Human Trials of the institution in which the survey was conducted and whether the procedures are in accordance with the 1995 Helsinki Declaration and the Ethics in Experimentation Animals, respectively. Authors should include a statement indicating that the protocol was approved by the Institutional Ethics Committee (affiliate institution of at least one of the authors), with its identification number. It should also include whether a Free and Informed Consent Term was signed by all participants.

Authors should precisely identify all drugs and chemicals used, including generic names, dosages and administration. Patients' names, initials, or hospital records should not be included. References regarding statistical procedures should be included.

RESULTS: Results should be present in logical sequence in the text, using tables and illustrations. Do not repeat in the text all the data in the tables and/or illustrations, but emphasize or summarize only the most relevant findings.

DISCUSSION: Emphasize new and important aspects of the study and the conclusions that derive from it, in the context of the best evidence available. Do not repeat in detail data or other information mentioned elsewhere in the manuscript, as in the Introduction or Results. For experimental studies it is recommended to start the discussion by briefly summarizing the main findings, then explore possible mechanisms or explanations for these findings, compare and contrast the results with other relevant studies, state the limitations of the study and explore the implications of these results for future research and for clinical practice.

Link the conclusions with the goals of the study, but avoid statements and conclusions that are not supported by the data, in particular the distinction between clinical and statistical relevance. Avoid making statements on economic benefits and costs, unless the manuscript includes data and appropriate economic analysis. Avoid priority claim ("this is the first study of ...") or refer to work that has not yet been completed.

CONCLUSION: The conclusion should be clear and concise, establishing a link between the conclusion and the study objectives. Avoiding conclusions not based on data from the study in question is recommended, as well as avoiding suggest that studies with larger samples are needed to confirm the results of the work in question.

ACKNOWLEDGEMENTS

When applicable, briefly acknowledge the people who have contributed intellectually or technically to the study, but whose contribution does not justify co-authorship. The author must ensure that people agree to have their names and institutions disclosed. Financial support for the research and fellowships should be acknowledged in this section (funding agency and project number).

AUTHORS IDENTIFICATION: The ORCID (Open Researcher and Contributor ID, <http://orcid.org/>) of each author should be informed in the authors' statement of contribution, according to the model below.

STATEMENT OF AUTHORS' CONTRIBUTION: The declaration of authors' contribution should be included at the end of the article, using minimum criteria for authorship, including:

- Substantial contribution in the work conception or design, or acquisition, analysis or interpretation of data to the study;
- Writing the article or critically reviewing its intellectual content;
- Approval of the final version of the manuscript to be submitted for publication;
- Agree to be responsible for all aspects of the work, to ensure that any matters regarding the completeness or accuracy of any of its parts are properly investigated and resolved;

All articles should include a description of the authors' contribution, as follows:

"Each individual author contributed individually and significantly to the development of this work. MJ (0000-0000-0000-0000)*: wrote and reviewed the and performed the surgeries; CPV (0000-0002-3904-2836)*: performed the surgeries, analyzed the data analysis and wrote the articles; JVC (0000-0003-3910-714x (0000-0000-0000-0000)*: performed statistical analysis, participated at the surgeries and reviewed the article; OMA (0000-0000-0000-0000)*: analyzed the slides and reviewed the article; MASP (0000-0000-0000-0000)*: drafted and reviewed the article and contributed to the intellectual concept of the study; ACA (0000-0001-6891-5935)*: performed the surgeries, wrote the article, performed statistical analysis and contributed to the intellectual concept of the study and the entire research project. *ORCID (Open Researcher and Contributor ID)."

REFERENCES: Original articles may include up to about 20 references, restricted to the essential bibliography to the article's content. Number the references consecutively in the order in which they are first mentioned in the text, using superscript Arabic numerals in the following format: (e.g., Reduction of terminal plate functions.¹).

Authors should make sure that all references are cited in the text. Several citations within a single set of parentheses should be separated by commas without space (^{1,5,7}). Where there are 3 or more sequential citations, use a numeric range (⁴⁻⁹). Include the first six authors followed by et al. The titles of journals should be abbreviated according to *Index Medicus*.

a) Article: Author (s). Article title. Journal title. Year; volume: initial page – final page.

Ex.: Campbell CJ. The healing of cartilage defects. *Clin Orthop Relat Res*. 1969;64:45-63.

b) Book: Author(s) or editor (s). Book title. Edition, if it is not the first. Translator (s), if it applies. Publication place: publisher; year.

Ex.: Diener HC, Wilkinson M, editors. Drug-induced headache. 2nd ed. New York: Spriger-Verlag; 1996.

c) Book chapter: Chapter author (s). Chapter title. Book Editor (s) and supplementary data, likewise the previous item.

Ex.: Chapman MW, Olson SA. Open fractures. In: Rockwood CA, Green DP. *Fractures in adults*. 4th ed. Philadelphia: Lippincott-Raven; 1996. p.305-52.

d) Abstract: Author(s). Title, followed by [abstract]. Journal. Year; volume (supplement and its number, if it applies); page (s).

Ex.: Enzensberger W, Fisher PA. Metronome in Parkinson's disease [abstract]. *Lancet*. 1996;34:1337.

e) Personal communications: should only be mentioned in the text, between parentheses.

f) Thesis: Author, title, level (Master, PhD, etc.), city: institution; year.

Ex.: Kaplan SJ. Post-hospital home health care: the elderly's access and utilization [dissertation]. St. Louis: Washington Univ.; 1995.

g) Electronic material: Author (s). Article title. Abbreviated Journal title [medium]. Publication date [access date followed by the expression "accessed on"]; volume (number):initial page-final page or [approximate number of pages]. URL followed by the expression "Available from:"

Ex.: Pavezi N, Flores D, Perez CB. Proposição de um conjunto de metadados para descrição de arquivos fotográficos considerando a Nobrade e a Sepiades. *Transinf. [Internet]*. 2009 [acesso em 2010 nov 8];21(3):197-205. Available from: <http://periodicos.puc-campinas.edu.br/seer/index.php/transinfo/article/view/501>

TABLES: Tables should be numbered in order of appearance in the text with Arabic numerals. Each table should have a title and, when necessary, an explanatory caption. Charts and tables should be sent in editable source files (Word, Excel) and not as images. Tables and charts covering more than one page should be avoided. Do not use image elements, text boxes, or tabs.

FIGURES (ILLUSTRATIONS AND PHOTOS): Figures should be submitted on separate pages and numbered sequentially in Arabic numerals, according to the order of appearance in the text. To avoid issues that compromise the journal pattern, all material sent shall comply with the following parameters: all graphics, photographs and illustrations should have adequate graphic quality (300 dpi resolution) and present title and caption. In all cases, the files must have .tif or .jpg extensions. Files with extension .xls, .xlsx (Excel), .eps or .psd to curve illustrations (graphics, drawings and diagrams) shall also be accepted. Figures include all illustrations such as photographs, drawings, maps, graphs, etc. Black and white figures will be freely reproduced, but the editor reserves the right to set a reasonable limit on their number or charge the author the expense resulting from excesses. Color photos will be charged to the author.

Please note that it is the authors' responsibility to obtain permission from the copyright holder to reproduce figures (or tables) that have been previously published elsewhere. Authors must have permission from the copyright owner, if they wish to include images that have been published in other non-open access journals. Permission shall be indicated in the figure legend and the original source must be included in the reference list.

LEGENDS TO FIGURES: Type the legends using double space, following the respective figures (graphics, photos and illustrations). Each legend must be numbered in Arabic numerals corresponding to each illustration and in the order they are mentioned in the text. Abbreviations and acronyms should be preceded by the full name when cited for the first time in the text. At the bottom of figures and tables discriminate the meaning of abbreviations, symbols, signs and other informed source. If the illustrations have already been published, they shall be accompanied by written consent of the author or editor, stating the reference source where it was originally published.

PAPER SUBMISSION: From January 2008 *Acta Ortopédica Brasileira* adopts the SciELO Publication and Submission System available online at <http://submission.scielo.br/index.php/aob/index>. Authors should follow the registration and article inclusion instructions available at the website.

For further information please contact Atha Comunicação e Editora. Rua Machado Bittencourt 190, 4° floor. Vila Mariana, 04044-000. São Paulo, SP Brazil. actaortopedicabrasileira@uol.com.br. Tel. +55 11 5087-9502 c/o Ana Carolina de Assis/Arthur T. Assis.

The journal's content, unless otherwise stated, is under Creative Commons Licence CC-BY-NC.

Levels of Evidence for Primary Research Question^a

(This chart was adapted from material published by the Centre for Evidence-Based Medicine, Oxford, UK.

For more information, please visit www.cebm.net.)

Types of study				
Level	Therapeutic Studies Investigating the Results of Treatment	Prognostic Studies – Investigating the Effect of a Patient Characteristic on the Outcome of Disease	Diagnostic Studies – Investigating a Diagnostic Test	Economic and Decision Analyses – Developing an Economic or Decision Model
I	High quality randomized trial with statistically significant difference or no statistically significant difference but narrow confidence intervals	High quality prospective study ^d (all patients were enrolled at the same point in their disease with ≥80% of enrolled patients)	Testing of previously developed diagnostic criteria on consecutive patients (with universally applied reference "gold" standard)	Sensible costs and alternatives; values obtained from many studies; with multiway sensitivity analyses
	Systematic review ^b of Level RCTs (and study results were homogenous ^c)	Systematic review ^b of Level I studies	Systematic review ^b of Level I studies	Systematic review ^b of Level I studies
II	Lesser quality RCT (eg, < 80% followup, no blinding, or improper randomization)	Retrospective ^f study	Development of diagnostic criteria on consecutive patients (with universally applied reference "gold" standard)	Sensible costs and alternatives; values obtained from limited studies; with multiway sensitivity analyses
	Prospective ^d comparative study ^e	Untreated controls from an RCT	Systematic review ^b of Level II studies	Systematic review ^b of Level II studies
	Systematic review ^b of Level II studies or Level I studies with inconsistent results	Lesser quality prospective study (eg, patients enrolled at different points in their disease or <80% followup)		
		Systematic review ^b of Level II studies		
III	Case control study ^g	Case control study ^g	Study of non consecutive patients; without consistently applied reference "gold" standard	Analyses based on limited alternatives and costs; and poor estimates
	Retrospective ^f comparative study ^e		Systematic review ^b of Level III studies	Systematic review ^b of Level III studies
	Systematic review ^b of Level III studies		Case-control study	
			Poor reference standard	
IV	Case series ^h	Case series		Analyses with no sensitivity analyses
V	Expert opinion	Expert opinion	Expert opinion	Expert opinion

^a A complete assessment of quality of individual studies requires critical appraisal of all aspects of the study design.

^b A combination of results from two or more prior studies.

^c Studies provided consistent results.

^d Study was started before the first patient enrolled.

^e Patients treated one way (eg, cemented hip arthroplasty) compared with a group of patients treated in another way (eg, uncemented hip arthroplasty) at the same institution.

^f The study was started after the first patient enrolled.

^g Patients identified for the study based on their outcome, called "cases" eg, failed total arthroplasty, are compared with patients who did not have outcome, called "controls" eg, successful total hip arthroplasty.

^h Patients treated one way with no comparison group of patients treated in another way.

ORIGINAL ARTICLES

FOOT

COMPARING OUTCOMES OF THE ANKLE ARTHRODESIS BY USING TWO DIFFERENT MATERIALS
VIA A TRANSFIBULAR APPROACH.....55

COMPARAÇÃO DOS RESULTADOS DA ARTRODESE DO TORNOZELO USANDO DOIS DIFERENTES MATERIAIS ATRAVÉS DE
UMA ABORDAGEM TRANSFIBULAR

Jun-Beom Kim, Bong-Ju Lee, Deukhee Jung, Uitak Jeong, Chunghan An

DOI: <http://dx.doi.org/10.1590/1413-785220202802223986>

PRE-PLANNING ANKLE ARTHRODESIS USING 3D RECONSTRUCTED TOMOGRAPHIES.....60

DESENVOLVIMENTO DA ARTRODESE DO TORNOZELO BASEADA NA TOMOGRAFIA COM RECONSTRUÇÃO 3D

*Rodrigo Schroll Astolfi, Marcio de Paiva Bezerra Carrah, Guilherme Farias Cordeiro, Jailson Rodrigues Lopes, Manuel Joaquim Diógenes Teixeira,
José Alberto Dias Leite*

DOI: <http://dx.doi.org/10.1590/1413-785220202802225457>

RELATIONSHIP BETWEEN QUALITY OF LIFE AND RADIOLOGICAL PARAMETERS AFTER HALLUX
VALGUS CORRECTION.....65

RELAÇÃO ENTRE A QUALIDADE DE VIDA E PARÂMETROS RADIOGRÁFICOS APÓS CORREÇÃO DO HÁLUX VALGO

Henrique Mansur, Vinicius Cardoso, Thomas Nogueira, Isnar Castro

DOI: <http://dx.doi.org/10.1590/1413-785220202802225507>

HIP

MEASUREMENT OF PELVIC RETROVERSION DURING HIP FLEXION: EVALUATION WITH ACCELEROMETERS69

MENSURAÇÃO DE RETROVERSÃO PÉLVICA DURANTE FLEXÃO DO QUADRIL: AVALIAÇÃO COM ACELERÔMETROS

Alexandre Junior Fenato, Larissa Martins Garcia, Gleici da Silva Castro Perdoná, Daniel Augusto Maranhão

DOI: <http://dx.doi.org/10.1590/1413-785220202802227237>

KNEE

ASSESSMENT OF THE USE OF TRANEXAMIC ACID AFTER TOTAL KNEE ARTHROPLASTY.....74

AVALIAÇÃO DO USO DO ÁCIDO TRANEXÂMICO DURANTE A ARTROPLASTIA TOTAL DO JOELHO

*Chilan Bou Ghosson Leite, Lucas Verissimo Ranzoni, Pedro Nogueira Giglio, Marcelo Batista Bonadio, Lucas da Ponte Melo, Marco Kawamura Demange,
Riccardo Gomes Gobbi*

DOI: <http://dx.doi.org/10.1590/1413-785220202802228410>

FACTORS AFFECTING THE FUNCTIONAL OUTCOME OF OXFORD PHASE 3 UNICOMPARTMENTAL KNEE ARTHROPLASTY 78

FATORES QUE AFETAM O RESULTADO FUNCIONAL DA ARTROPLASTIA UNICOMPARTIMENTAL DO JOELHO OXFORD PHASE 3

Ayşe Esin Polat, Barış Polat, Tahsin Gürpınar, Barış Peker, Tolga Tüzüner

DOI: <http://dx.doi.org/10.1590/1413-785220202802225137>

SHOULDER

LATARJET PROCEDURE ON ANTERIOR SHOULDER INSTABILITY IN PROFESSIONAL SOCCER PLAYERS..... 84

CIRURGIA DE LATARJET NA INSTABILIDADE ANTERIOR DO OMBRO EM JOGADORES PROFISSIONAIS DE FUTEBOL

Guilherme Augusto Stirna, Ewerton Borges de Souza Lima, Deginaldo Holanda Chaves, Paulo Santoro Belangero, Carlos Vicente Andreoli, Benno Ejinisman

DOI: <http://dx.doi.org/10.1590/1413-785220202802225433>

TREATMENT OF MIDSHAFT CLAVICLE FRACTURE WITH SUPERIOR PLATE PLACEMENT..... 88

TRATAMENTO PARA FRATURA DA DIÁFISE DA CLAVÍCULA COM INSERÇÃO DE PLACA ÓSSEA SUPERIOR

Bekir Eray Kilinc, Yunus Oc, Ramazan Erden Erturer

DOI: <http://dx.doi.org/10.1590/1413-785220202802226166>

SPINE

CHANGES IN THE LUMBAR VERTEBRAL SEGMENT RELATED TO THE CAGE POSITION IN TLIF TECHNIQUE..... 92

ALTERAÇÕES DO SEGMENTO VERTEBRAL LOMBAR RELACIONADAS À POSIÇÃO DO CAGE NO TLIF

Thiago Dantas Matos, Rodrigo Barra Caiado Fleury, Kelsen de Oliveira Teixeira, Valéria Romero, Helton Luiz Aparecido Defino

DOI: <http://dx.doi.org/10.1590/1413-785220202802224215>

TRAUMA

EPIDEMIOLOGICAL PROFILE OF MOTORCYCLE ACCIDENT VICTIMS IN UNIVERSITY HOSPITAL..... 97

PERFIL EPIDEMIOLÓGICO DE VÍTIMAS DE ACIDENTES DE MOTO EM HOSPITAL UNIVERSITÁRIO

Cintia Kelly Bittar, Alberto Cliquet Júnior, Vinicius Samuel Dias Alves da Costa, Ana Carolina de Freitas Pacheco, Renato Lazarin Ricci

DOI: <http://dx.doi.org/10.1590/1413-785220202802230035>

COMPARING OUTCOMES OF THE ANKLE ARTHRODESIS BY USING TWO DIFFERENT MATERIALS VIA A TRANSFIBULAR APPROACH

COMPARAÇÃO DOS RESULTADOS DA ARTRODESE DO TORNOZELO USANDO DOIS DIFERENTES MATERIAIS ATRAVÉS DE UMA ABORDAGEM TRANSFIBULAR

JUN-BEOM KIM¹ , BONG-JU LEE¹ , DEUKHEE JUNG¹ , UITAK JEONG¹ , CHUNGHAN AN¹ 

1. Daejeon Sun Medical Center, Department of Orthopedic Surgery, Daejeon, Republic of Korea.

ABSTRACT

Objective: To compare clinical and radiologic results and complications of patients who underwent arthrodesis using a transfibular approach with either a cannulated screw or an anterior fusion plate. **Methods:** Patients who underwent ankle arthrodesis were divided into two groups according to the used materials: 6.5 mm cannulated screw (A) and anterior fusion plate (B). The clinical scores were compared between groups. The radiologic results were then assessed by union time. The results were statistically analyzed using SPSS 20. **Results:** There was no significant difference between both groups in the American Orthopedic Foot & Ankle Society (AOFAS) score ($p = 0.75$), and in the visual analog scale ($p = 0.42$). In group B, two cases included wound infection at the surgical site. In group A, the mean union time was 10.5 ± 2.3 weeks. In group B, it was 7.8 ± 1.3 . There was a statistically significant difference ($p = 0.007$) between union time in both groups. **Conclusion:** Anterior fusion plate is an effective method for shorter union time, but the surgeon should be careful with the surgical wound at the skin incision site in the lesion of the distal tibia. **Level of Evidence III, Retrospective comparative study.**

Keywords: Ankle Joint. Osteoarthritis. Arthrodesis.

RESUMO

Objetivo: Comparar os resultados clínicos e radiológicos assim como as complicações de pacientes sujeitos a artrodeose de abordagem transfibular com o uso de parafuso canulado ou placa óssea anterior. **Métodos:** Pacientes sujeitos a artrodeose do tornozelo foram divididos em dois grupos de acordo com os materiais usados: parafuso canulado de 6,5 mm (A) e placa óssea anterior (B). Os escores clínicos de ambos os grupos foram comparados e os resultados radiológicos foram avaliados de acordo com o tempo de união óssea. Os resultados foram analisados estatisticamente usando SPSS 20. **Resultados:** Não houve diferença significativa entre os grupos quanto ao escore American Orthopedic Foot & Ankle Society (AOFAS) ($p = 0,75$) e a escala visual analógica ($p = 0,42$). No grupo B, ocorreu infecção na área da cirurgia em dois casos. No grupo A, a média de tempo de união foi de $10,5 \pm 2,3$ semanas. No grupo B, este foi de $7,8 \pm 1,3$. Constatou-se diferença estatisticamente significativa ($p = 0,007$) quanto ao tempo de união em ambos os grupos. **Conclusão:** Os autores concluíram que a placa óssea anterior é um método eficiente para tempos de união curtos, porém o cirurgião deve ficar atento à ferida cirúrgica na área de incisão da pele em casos de lesão na tibia distal. **Nível de Evidência III, Estudo retrospectivo comparativo.**

Descritores: Articulação do Tornozelo. Osteoartrite. Artrodeose.

Citation: Kim JB, Lee BJ, Jung D, Jeong U, An CH. Comparing outcomes of the ankle arthrodesis by using two different materials via a transfibular approach. Acta Ortop Bras. [online]. 2020;28(2):55-9. Available from URL: <http://www.scielo.br/aob>.

All authors declare no potential conflict of interest related to this article.

Correspondence: Jun-Beom Kim. 29 Mokjung-ro, Jung-gu, Daejeon, Republic of Korea, 34811. kjb9290@gmail.com



INTRODUCTION

Ankle arthrodesis in end-stage ankle osteoarthritis is still a treatment of choice for this condition due to its short learning curve, short-term follow-up, and fewer complications compared to other treatments, such as failure of implants.¹⁻⁴

There are many reports about the approach and the fixation method for the arthrodesis,¹ including arthroscopic and open arthrodesis.

The required time for the arthroscopic ankle arthrodesis may be longer than that for the open arthrodesis depending on the surgeon's proficiency.^{5,6} In addition, arthroscopic ankle arthrodesis has a disadvantage, because it cannot be performed when there is more than 5° varus or valgus deformities or in the case of a severe bone defect.⁷ Because of such advantages, open arthrodesis is commonly used.

Open approaches include anterior, transfibular, and posterior methods. Among them, the transfibular approach is widely used because it provides enough operation field of view with the advantage of avoiding anterior neurovascular injuries or injury of the posterior deep flexor tendon.⁴ The fixation materials for arthrodesis are the following: cannulated screw, cancellous screw, or plate. Cannulated screw fixation is the most commonly used one to apply a compression force to the fusion site.⁸ Arthrodesis with anterior fusion plate has been reported recently.⁹⁻¹¹ Although there are many studies reporting results for each fixation material,^{1,4} studies that compare these materials are insufficient. This study aims to compare clinical and radiologic results, complications of patients who underwent an arthrodesis using a 6.5 mm cannulated screw, and those who underwent arthrodesis using the same approach with an anterior fusion plate.

MATERIALS AND METHODS

Patient population

The study plan and the patient's data analysis were approved by the Institutional Review Board (IRB number: DSH-인-19-14) of Sun Medical Center. All participants signed an informed consent form. From August 2011 to August 2017, 24 patients (24 cases) underwent arthrodesis due to end-stage osteoarthritis of ankle joints with more than 5° of varus or valgus ankle joint deformity (Figure 1). All cases were performed with the transfibular approach. In group A, 12 cases underwent arthrodesis with three 6.5 mm cannulated screw (Biomet Trauma, IN, USA) (Figure 2), and 12 cases in group B, with anterior fusion plate (Arthrex Inc, FL, USA) (Figure 3). After choosing the fixation materials from the two groups, screws were used in group A in February 2017, in Korea, before the introduction of the anterior fusion plate in group B, which was then performed. The mean patients' age at the time of surgery for group A was 56.9 years (ranging from 33 to 69 years old) and 64.1 years for group B (ranging from 53 to 81 years old). The mean follow-up period was 15.4 months for group A (ranging from 13 to 27 months) and 14.8 months for group B (ranging from 12 to 18 months). There were no statistically significant differences in sex, body mass index (BMI), mean age, diabetes mellitus (DM), smoking, surgical side, durations of symptom, and mean follow-up period between the two groups (Table 1).

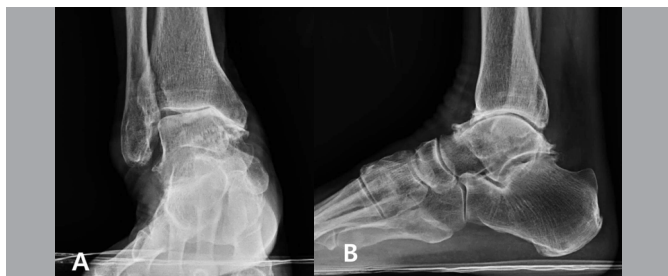

Figure 1. Plain radiographs showing end-stage arthritis in the ankle joint through anteroposterior (AP) view (A) and lateral view (B).



Figure 2. Plain radiographs showing an arthrodesis from group A using the 6.5 mm cannulated screw (Biomet Trauma, Indiana, USA) and complete fused ankle joint on AP view (A) and lateral view (B).

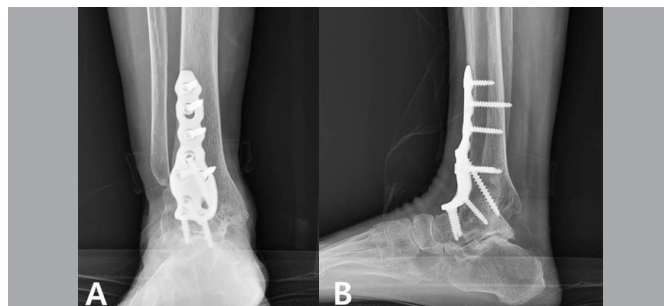

Figure 3. Plain radiographs showing an arthrodesis from group B with anterior fusion plate (Arthrex Inc, Florida, USA) and complete fused ankle joint on AP view (A) and lateral view (B).

Table 1. A statistical description of the case series (N = 24).

	Group A (n = 12)	Group B (n = 12)	P*
Sex (M:F)	8:4	7:5	0.347
Mean age (years)	56 (33 to 69)	64 (53 to 81)	0.235
BMI (kg/m ²)	23.1 3.0	25.2 4.5	0.786
Surgical Side (Left:Right)	5:7	3:9	0.413
DM	2 (16%)	4 (33%)	0.566
Smoking	4 (34%)	3 (25%)	0.651
Follow-up period (months)	15.4 5.1	14.8 2.0	0.786
VAS score at final follow-up	2.3 0.6	2.4 0.5	0.487
AOFAS Ankle-Hindfoot score	64.4 6.1	65.3 5.5	0.525
Union time (weeks)	10.5 2.3	7.8 1.3	0.007
Complications			
Skin necrosis	0 (0%)	2 (16%)	NA

The values are given as mean ± standard deviation. P*: p-value, Mann-Whitney test comparing group A and B; p-value < 0.05 indicates statistical significance; BMI: body mass index (kg/m²); DM: Diabetes Mellitus; Smoking: more than 10 packs/years; VAS: visual analog scale; AOFAS Ankle-Hindfoot score: American Orthopedic Foot and Ankle Society Ankle-Hindfoot score; NA: not applicable.

Surgical technique & postoperative management

The patients on the operating table underwent spinal or general anesthesia using a typical tourniquet in the supine position. For the transfibular approach, an incision was made over the posterior half of the fibula, starting from 8 to 10 cm proximal to the tip of the fibula (Figure 4A). If more skin incision was needed, another incision was made curving anteriorly and distally over the sinus tarsi for another 2 to 4 cm toward the base of the fourth metatarsal. The approach used the internervous plane between the sural nerve posteriorly and the superficial peroneal nerve anteriorly. When performing the dissection at the level of the fibula, full-thickness flaps were created and a subperiosteal dissection was performed to minimize soft tissue

tension. A fibular osteotomy was performed from 3 to 5 cm proximal to the level of the ankle joint. An oblique osteotomy from proximal lateral to distal medial was preferred. The cut edge was beveled to avoid creating bony prominence. Using a micro sagittal saw in the sagittal plane, the medial third of the fibula was removed, morselized, saved as bone graft, and then it was trimmed as a structural and bone chip type.

Fibular bone graft was performed in all cases, because this study speculated that it could reduce the risk of shortening the limb length and that it maintained the stable fusion construct. Although there were many methods of autogenic bone graft, the study used only the fibular structural bone harvest via a transfibular approach, because it could achieve an appropriately structural bone graft and had no additional incisions for the harvest.

A joint distractor or laminar spreader was used to fully expose the tibial plafond and the dome of the talus. Tibial plafond and talar dome preparations were performed with transverse flat cuts. The residual articular cartilage was removed with an osteotome, a curette, and a high-speed burr, exposing the subchondral bone. The medial side of the ankle joint was exposed by the anterior approach between the extensor hallucis longus and the tibialis anterior. The medial cartilage of the talus and tibia was then removed. When a plate was used for arthrodesis, the anterior skin incision was extended over the proximal portion to the distal tibia. The skin incision was carefully made at that time. The anterior skin incision should be sufficiently spaced (more than 5 cm) from the lateral skin incision (Figure 4B). The skin incision interval aimed to prevent skin necrosis at the incision site. The cartilage was removed, and the ankle alignment was adjusted to a neutral extension, 5° of valgus, 5° of external rotation, and hindfoot posteriorly. A 6.5 mm cannulated screw or anterior fusion plate was used for the arthrodesis with an autogenous bone graft from a fibular bone. In screw fixation methods, three cannulated compression screws were applied at 45 degrees on the long axis of the tibia; two of them were into the medial side of the tibia from the lateral side of the talus, and one was into the anterior neck of the talus from posterior surface of the tibia, which is called 'home run screw.'

In the anterior plate method, the ankle was temporarily fixed in a proper position by the Kirschner wire. After the plate was applied, the locking screw was used through the distal talar holes. The compression force in the ankle joint was obtained by placing a nonlocking screw eccentrically in the oblong compression hole on the tibial portion of the plate, and the fixation was continued in the anatomic lag screw hole and in the remained proximal plate holes.

In all cases, the suture was removed postoperatively after two weeks. Short leg cast immobilization and non-weight-bearing were performed for 6 weeks. At 6 weeks, partial-weight-bearing was allowed using walking cast or cam walker boot. Only at 8 weeks the full-weight-bearing was allowed using a cam boot.



Figure 4. Pictures showing the preparation of skin incision for the approach. We prepared the skin incision for transfibular approach (A). And then, the designed skin incision over the posterior half of the fibular, starting from 8 to 10 cm proximal to the tip of the fibula. Interval between the transfibular approach (asterisk) and the anterior approach (arrow) at more than 5 cm (B).

Clinical and radiologic assessment

The clinical assessment used “the American Orthopedic Foot and Ankle Society Ankle-Hindfoot” Score (“AOFAS hindfoot-ankle” score)^{12,13} and the Visual Analog Score (VAS) before and after the surgery. Postoperative complications, such as wound infection and metal failure, were recorded. The radiologic assessment was performed at 2, 3, 6, 9, and 12 months postoperatively. Plain radiographs were taken at standing posture to confirm the fixation and the fusion status.

The fusion of joints was judged to be united when more than 50% of the ankle joint surface was connected on the anteroposterior and on the lateral plain radiographs. The delayed union was defined as a symptom of pain with the absence of union evidence for more than 6 months on radiographs and nonunion lasting for more than 12 months.⁸

Clinical scores, radiographic assessment, and period of the union were recorded for all cases and the statistical comparison was made between the two groups. The statistical tests were performed using the Kolmogorov-Smirnov test, the Leven's test, the Multiple linear regression analysis, the Mann-Whitney test, and the Wilcoxon signed rank test using SPSS 20 (IBM, Inc, New York, NY, USA). This study defined statistical significance level at 5% ($p \leq .05$).

RESULTS

Clinical results

“AOFAS hindfoot-ankle” score in group A was significantly increased ($p = 0.003$) from 43.3 ± 4.3 preoperatively to 64.4 ± 6.1 after the surgery. In group B, it was also significantly increased ($p = 0.002$) from 44.3 ± 4.3 preoperatively to 65.3 ± 5.5 after the surgery. However, there was no significant difference in this score between the two groups ($p = 0.525$) (Table 2).

In group A, the mean preoperative VAS was 7.3 ± 1.0 , significantly improved ($p = 0.003$) to 2.3 ± 0.6 after the surgery. In group B, the mean preoperative VAS was 7.5 ± 0.9 and also significantly improved ($p = 0.002$) to 2.4 ± 0.5 after the surgery. There was no statistically significant difference ($p = 0.487$) in the VAS between the two groups (Table 2).

Nonunion was not observed in both groups. In group B, two cases had wound infection at the surgical site (Figure 5A), and the patients were being treated for diabetes mellitus. One of them underwent skin grafting surgery with full-thickness skin flap of the ipsilateral thigh (Figure 5B), while the other one underwent simple dressing and wound healing (Figure 5C). Neither case progressed to deep infection. The infection did not affect the bone union.

Table 2. Preoperative and Postoperative VAS and AOFAS scores in the Groups, A and B

	Outcomes	Preoperative	Postoperative	p-value
Group A (6.5 mm cannulated screw)	VAS	7.3 1.0	2.3 0.6	0.003
	AOFAS Ankle hindfoot score	43.3 4.3	64.4 6.1	0.003
Group B (Anterior fusion plate)	VAS	7.5 0.9	2.4 0.5	0.002
	AOFAS Ankle hindfoot score	44.3 4.3	65.3 5.5	0.002

Wilcoxon signed rank test comparing preoperative and postoperative in both groups
p-value < 0.05 indicates statistical significance; VAS: visual analog scale; AOFAS Ankle-Hindfoot score: American Orthopedic Foot and Ankle Society Ankle-Hindfoot score.

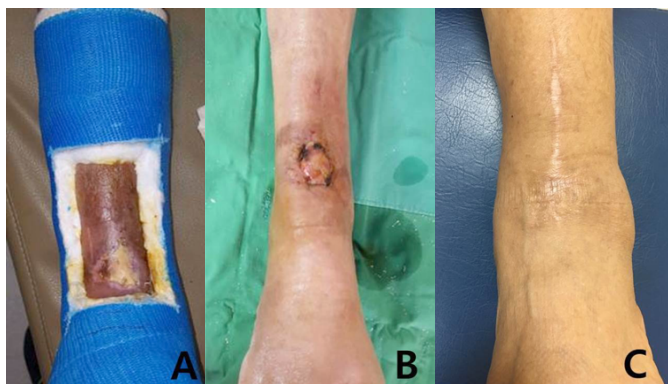

Figure 5. Pictures showing wound problems and the healing process. Surgical site infection occurred in Group B (A). The skin graft was done at infected surgical site (B). The wound was healed at infected surgical site after simple dressing (C).

Radiological results

All cases obtained fusion status in group A. The mean union time was 10.5 ± 2.3 weeks. In group B, fusion was achieved for all 12 cases. The mean union time was 7.8 ± 1.3 . A statistically significant difference ($p = 0.007$) was observed in the mean union time between the two groups.

Statistical analysis

The Kolmogorov-Smirnov test was used to confirm the normal distribution of the data in each group. The Levin's test was used to determine the equilibrium distribution of data between the two groups. The Mann-Whitney test and the Wilcoxon signed rank test were used to compare the results. Multiple linear regression analysis revealed that sex, age, DM, smoking, duration of symptom and BMI were not associated with clinical or radiological results.

DISCUSSION

Ankle arthrodesis is the most commonly used surgical procedure for the treatment of end-stage ankle osteoarthritis. Many approaches (medial, lateral, anterior, and posterior) and fixed materials have been introduced since the first report of the anterior approach by Albert.¹⁴ In general, the anterior and lateral approach are widely used.⁴ The lateral approach is also called the transfibular approach, and useful when it is necessary to do additional fibular osteotomy.¹⁵

The anterior approach can reach all ankle joint surface. However, it has limited access to the medial and lateral malleolus. It is an attentive approach that can injure the anterior vasculature.

However, the transfibular approach is in general easier to expose than the anterior approach. Due to the use of a full-thickness flap, there is less possibility of skin problems and fewer complications.¹⁶

In this study, all cases were performed by a transfibular approach. The most common method of arthrodesis is cannulated screw fixation that can exert a compressive force on the union site. Many studies about union rate, long-term follow-up results, and subsequent complications were performed.¹⁷ Recently, several methods using an anterior fusion plate have been introduced.⁹⁻¹¹ However, there are few comparative studies of plate fixation and cannulated screw fixation.

This study compared 12 cases of cannulated screw fixation and 12 cases of anterior fusion plate fixation via a transfibular lateral approach. As a result, clinical scores in each group were significantly improved after surgery, similar to those reported in previous studies.⁸⁻¹⁰ However, these scores were not significantly different between the two groups. Bone union time was measured at 10.5 weeks for group A and 7.8 weeks for group B. Group B showed significantly faster bone union ($p = 0.007$) than the group A.

Guo et al.⁹ has reported anterior fusion plate fixation performed in 10 cases of end-stage ankle arthritis. In 9 cases with mean 15 weeks follow-up, screw loosening after screw fixation resulted in a union period of 12 weeks in one anterior plate fixation. Although shorter union time was observed in this study, a simple comparison is not possible for those factors that affect the bone union.

According to Park et al.⁸, the union period of cannulated screw fixation was between 6 weeks and 40 weeks, with an average of 9 weeks. The results of their study were similar to those of the screw fixation group in this study. However, their study did not consider all factors affecting the bone union either. With both methods, the results of the union period were not significantly different.

Common complications of ankle arthrodesis are nonunion, malunion, wound infection, deep soft tissue infection, and arthritis of adjacent joints after a long-term follow-up.¹⁷ Mark et al.¹⁰ has reported that nonunion rates are high when arthrodesis of post-traumatic arthritis is performed and that nonunion tends to be due to smoking, history of diabetes, alcohol and illicit drug use, and psychiatric history. According to Zwipp H et al.¹⁶, screw fixation performed in a neutral posture of the ankle has a high fusion rate and low complication rate, with satisfactory functional results at mid-term follow-up.

Many long-term follow-up results have reported an incidence of osteoarthritis in adjacent joints, a typical complication of the nonunion.⁸ However, additional arthrodesis and surgical treatment about these complications remain controversial.

With an anterior approach using an anterior AO-T plate, 31 (94%) of a total of 33 cases achieved fusion. The incidence of complications was relatively low, and the technique was reported to be simple and stable.¹¹ In addition, Mark A et al.¹⁰ has compared nonunion rates of patients who underwent anterior locking fusion plate fixation and screw fixation. One case (2.1%) of patients with an anterior plate (47 cases) reported nonunion in the Mark A et al. study, and the patients using screw fixation reported 4 cases (11.1%). Therefore, the nonunion rate did not differ between the two groups.

In this study, there were no nonunions in both groups ($n = 24$) and two cases of wound infection (16%, 2/12) occurred in the anterior part of the distal tibia in group B. However, nonunions were not observed in these two cases.

In 2 cases, which had wound problem, had no DM, smoking, and other underlying disease.

A possible cause of the wound problem might be the tightness of the sutured wound.

This study has some limitations.

First, there are few cases studied. This study considered that the validity of the statistical analysis could be lower. Second, there were short term results. Long-term follow-up results are needed to observe more complications, such as an incidence of arthritis in the adjacent joint. To confirm the findings of this study, more prospective analysis and comparison with other approaches are

needed, along with more cases and long-term follow-up results for wound infection of the anterior skin of the distal tibia.

CONCLUSION

In conclusion, the anterior fusion plate in the treatment of end-stage ankle osteoarthritis was superior to a cannulated screw in bone

union time. However, complications, such as wound problems, were more common than with the screw method.

The authors concluded the anterior fusion plate is an effective method for the shorter union time, but the surgeon should be careful because of the wound at the skin incision site in the distal tibia lesion.

AUTHORS' CONTRIBUTIONS: Each author individually and significantly contributed to the development of this article. JBK: writing, reviewing, and performing surgeries; BJL: data analysis and writing; DJ: statistical analysis and review; UJ: data analysis and review; CA: writing and statistical analysis.

REFERENCES

1. Benich MR, Ledoux WR, Orendurff MS, Shofer JB, Hansen ST, Davitt J, et al. Comparison of Treatment Outcomes of Arthrodesis and Two Generations of Ankle Replacement Implants. *J Bone Joint Surg Am.* 2017;99(21):1792-800.
2. Gross C, Erickson BJ, Adams SB, Parekh SG. Ankle Arthrodesis After Failed Total Ankle Replacement: a systematic review of the literature. *Foot Ankle Spec.* 2015;8(2):143-51.
3. Hopgood P, Kumar R, Wood PL. Ankle Arthrodesis for Failed Total Ankle Replacement. *J Bone Joint Surg Br.* 2006;88(8):1032-8.
4. Lee DY, Sung IH. Ankle Arthrodesis. *J Korean Foot Ankle Soc.* 2011;15(3):124-31.
5. Nielsen KK, Linde F, Jensen NC. The Outcome of Arthroscopic and Open Surgery Ankle Arthrodesis: a comparative retrospective study on 107 patients. *Foot Ankle Surg.* 2008;14(3):153-7.
6. Myerson MS, Quill G. Ankle Arthrodesis: a comparison of an arthroscopic and an open method of treatment. *Clin Orthop Relat Res.* 1991;(268):84-95.
7. Chung HJ, Bae SY, Shin YW, Lim DJ, Cho SI. Outcomes of Lateral Malleolar Saving versus Sacrificing Procedure in Transfibular Ankle Arthrodesis. *J Korean Foot Ankle Soc.* 2010;14(2):135-9.
8. Pak CH, Lee JY, Jeong YJ. Ankle Arthrodesis Outcomes in Ankle Osteoarthritis: Comparison between anterior approach and transfibular approach. *J Korean Foot Ankle Soc.* 2014;18(4):189-94.
9. Guo C, Yan Z, Barfield WR, Hartsock LA. Ankle Arthrodesis Using Anatomically Contoured Anterior Plate. *Foot Ankle Int.* 2010;31(6):492-8.
10. Prissel MA, Simpson GA, Sutphen SA, Hyer CF, Berlet GC. Ankle Arthrodesis: A retrospective analysis comparing single column, locked anterior plating to crossed lag screw technique. *J Foot Ankle Surg.* 2017;56(3):453-6.
11. Rowan R, Davey K. Ankle Arthrodesis Using an Anterior AO T Plate. *J Bone Joint Surg Br.* 1999;81(1):113-6.
12. Kitaoka HB, Alexander IJ, Adelaar RS, Nunley JA, Myerson MS, Sanders M. Clinical Rating Systems for the Ankle-Hindfoot, Midfoot, Hallux, and Lesser Toes. *Foot Ankle Int.* 1994;15(7):349-53.
13. Ibrahim T, Beiri A, Azzabi M, Best AJ, Taylor GJ, Menon DK. Reliability and Validity of the Subjective Component of the American Orthopaedic Foot and Ankle Society Clinical Rating Scales. *J Foot Ankle Surg.* 2007;46(2):65-74.
14. Albert E. Einige fälle Künstliche Ankylosen. *Bildung an Paralytischen Gliedmassen.* *Wien Med Presse.* 1882;23:725-8.
15. Akra GA, Middleton A, Adedapo AO, Port A, Finn P. Outcome of Ankle Arthrodesis Using a Transfibular Approach. *J Foot Ankle Surg.* 2010;49(6):508-12.
16. Zwipp H, Rammelt S, Endres T, Heineck J. High Union Rates and Function Scores at Midterm Followup With Ankle Arthrodesis Using a Four Screw Technique. *Clin Orthop Relat Res.* 2010;468(4):958-68.
17. Fuchs S, Sandmann C, Skwara A, Chylarecki C. Quality of Life 20 Years After Arthrodesis of the Ankle. *J Bone Joint Surg Br.* 2003;85(7):994-8.

PRE-PLANNING ANKLE ARTHRODESIS USING 3D RECONSTRUCTED TOMOGRAPHIES

DESENVOLVIMENTO DA ARTRODESE DO TORNOZELO BASEADA NA TOMOGRAFIA COM RECONSTRUÇÃO 3D

RODRIGO SCHROLL ASTOLFI¹ , MARCIO DE PAIVA BEZERRA CARRAH² , GUILHERME FARIAS CORDEIRO² ,
JAILSON RODRIGUES LOPES³ , MANUEL JOAQUIM DIÓGENES TEIXEIRA² , JOSÉ ALBERTO DIAS LEITE¹ 

1. Universidade Federal do Ceará, Fortaleza, CE, Brazil.

2. General Hospital of Fortaleza, Fortaleza, CE, Brazil.

3. Boghos Boyadjan Clinic, Fortaleza, CE, Brazil.

ABSTRACT

Objective: To implement one analysis method of the ankle bone contour that could make a more precise ankle arthrodesis. **Methods:** Twenty tomographies were submitted to 3D reconstruction. Seven points of anatomic interest for ankle arthrodesis with the three screws technique were marked with a triplanar marker. The median of the position of markers was estimated, and the union of the seven median points allow the construction of one median ankle for that population. Using this median ankle, sizes and angles for the screws position were determined. **Results:** Two median ankles were reconstructed, left and right. The position of the screw passage were determined considering the anatomical parameters. In the right ankle the lateral to medial screw should enter 4.56 cm and 0.79 above and posterior to lateral malleolus, with one inclination of 17.34° in relation to tibial longitudinal axis; and 0° in relation to tibial axial plane. The position for the other two screws is also described. **Conclusion:** Our article is the first to presents one precise guide for ankle arthrodesis based on a populational assessment. **Level of evidence II, Diagnostic Studies.**

Keywords: Foot. Ankle. Arthrodesis. Pre-Planning. 3D-Reconstruction. Joint Diseases.

RESUMO

Objetivo: Implementar método de análise do contorno e alinhamento ósseos no tornozelo de uma população normal, possibilitando uma artrodeose tibiotársica mais precisa. **Métodos:** Tomografias de vinte tornozelos foram submetidas à reconstrução 3D. Nesses exames, 7 pontos anatômicos de interesse para a técnica de fixação com 3 parafusos foram identificados e marcados com indicadores da posição triplanar. As médias das localizações de cada ponto foram calculadas. A união dessas médias permitiu a reconstrução de um tornozelo padrão daquela população. Nesses tornozelos médios estudou-se os comprimentos e ângulos para a passagem dos parafusos. **Resultados:** Dois tornozelos, direito e esquerdo, foram reconstruídos. A posição para a passagem dos parafusos em relação a parâmetros anatômicos foi determinada. Para o tornozelo direito, a passagem do parafuso de lateral para medial deve ocorrer com o ponto de entrada 4,56 cm acima e 0,79 cm posterior à ponta do maléolo lateral, com inclinação de 17,34° em relação ao eixo longitudinal e 0° em relação ao eixo axial da tibia. As posições dos outros dois parafusos também estão descritas. **Conclusão:** Esse é o primeiro trabalho que apresenta um guia preciso para realização da artrodeose do tornozelo, baseado em um estudo populacional. **Nível de evidência II, Estudos Diagnósticos.**

Descritores: Artropatias. Pé. Tornozelo. Artrodeose. Pré-Planejamento. Reconstrução 3D.

Citation: Astolfi RS, Carrah MPB, Cordeiro GF, Lopes JR, Teixeira MJD, Leite JAD. Pre-planning ankle arthrodesis using 3D reconstructed tomographies. *Acta Ortop Bras.* [online]. 2020;28(2):60-4. Available from URL: <http://www.scielo.br/aob>.

INTRODUCTION

Ankle arthrodesis (AA) is a procedure for salvation in advanced ankle arthrosis. Despite the new techniques such as ankle arthroplasty, it is the only possible procedure in the case of young patients or bone defects. In addition, many studies have shown similar complication scans and quality of life between procedures.¹⁻³

Many studies have compared different forms of fixation.^{4,5} Screw fixation is the most traditional method, usually made with two crossed screws, one with medial entry and the other with entry.^{3,6,7} A third screw was generally added to the anteroposterior axis due to the high incidence of non-consolidations, usually with posterolateral entry into the tibia towards the neck of the talus, known as "home-run" screw (Figures 1 and 2).⁷⁻¹⁰

All authors declare no potential conflict of interest related to this article.

This study was developed at Universidade Federal do Ceará, Department of Surgery.

Correspondence: Rodrigo Schroll Astolfi. Av. Desembargador Moreira 760, 8° andar, Fortaleza, CE, Brazil, 60125160. dr.rodriagoastolfi@gmail.com

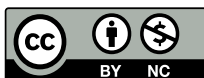



Figure 1. Fixing technique with 3 screws.



Figure 2. Fixing technique with 3 screws.

The screw is positioned to confront the strong deformation force of the Achilles tendon.¹¹⁻¹³ The stability of arthrodesis made only with the screws seems to be sufficient.^{5,11} But plates are often used to neutralize rotation forces along the screws.^{9,14,15} Additional stability increased consolidation rates;⁸ however, plates cannot be used in some cases as in arthroscopic arthrodesis.

Most parameters used to determine surgery with good alignment and good position of screws use postoperative radiographs with load. As this type of examination is not likely to be performed intra-operatively, the surgeon may have difficulty in positioning and passing the screws.¹⁶

Thus, the best form of guiding the surgeon are the anatomical references. Although several studies show the functional results of the fixation technique with three screws^{5,6,17,18}, we did not find studies on the anatomical population variation of the ankle and reference points that could be used by the surgeon for screw fixation and bone positioning.

Our study showed a cheap and simple method of study with a group of individuals without anatomical anomalies to create a practical guide for positioning and fixation in ankle arthrodesis, using 3D reconstruction of scans.

METHODS

This is a retrospective study with access to the archive of tomographic images of the General Hospital of Fortaleza approved by the Ethics Committee of the Institution under the opinion number: 2.889.433, wherein the signing of an informed consent form was not necessary. We selected 20 tomographies of 13 patients, 8 men and 5 women, aged between 18 and 70 years (10 left and 10 right ankles) to study the ideal positioning between the ankle bones and the best points of passage of the screws in the ankle arthrodesis.

We used the tripod fixation technique with two crossed screws, one entry and one of medial entry. In addition to entry screw known as "home run screw," as described by Schuberth et al.¹⁹, the tests were performed on a platform that kept the foot at 90°, positioned relative to the tibia. The images were obtained from the medical archive after approval by the ethics committee of the General Hospital of Fortaleza. Only ankles without bone misalignment or deformities were included according to evaluation of a radiologist and an orthopedist for each ankle.

The device used was the multislice tomography (Toshiba Medical System Corporation) with cuts of 1 mm. Using the Horos program (GNU Lesser General Public License®), the 104 tomographies were reconstructed three-dimensionally adjusting the density parameters for the best possible bone contour definition. Initially, we scored a standard zero point on all images and from these points we scored 8 points (Figure 3):

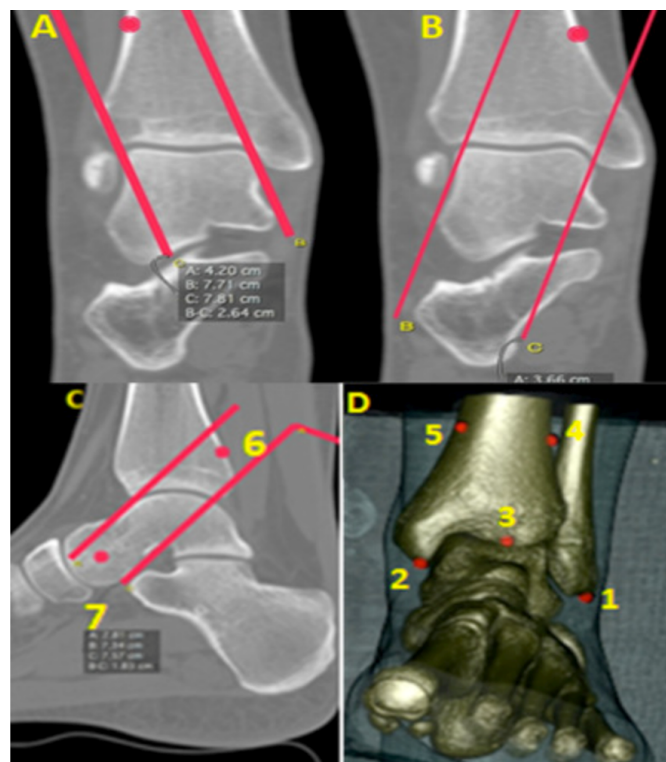

Figure 3. Marking of the entry points of the screws and anatomical reference points. A: determination of the lateral entry point in the middle distance of two parallel lines within the limits of the talus in the anteroposterior incidence and just anterior point of the fibula in the profile; B: medial entry point, half distance of two parallel lines within the limits of the talus at the most central point of the tibia in the profile; C: posterior entry point determined by two parallel lines within the limits of the talus in the profile and the center point of the talus head determined as the center of a circumference between the upper point of the talus head and the lower point; D: 3D reconstruction image.

1. lateral malleolus (more distal point of fibula)
2. medial malleolus (most distal point of tibia)
3. most anterior point of tibial pestle
4. Entry point of the medial screw
5. Entry point of the medial screw
6. Entry point of the posterior screw
7. Upper talus point
8. lower point of the talus (we defined the center of the circumference made between these last two points as the center of the talus)

The program generated the reference in the X, Y, and Z planes for each point from the given zero point. We estimated the mean compiling the data and confidence interval (CI) by simple inferential analysis for each plane of each point. Each midpoint was marked in the AutoCAD graphic design program®, generating the average ankle of the study population (Figure 4). The relationship between the points was analyzed and a guide for the passage of the screws and intraoperative positioning of the ankle was generated.

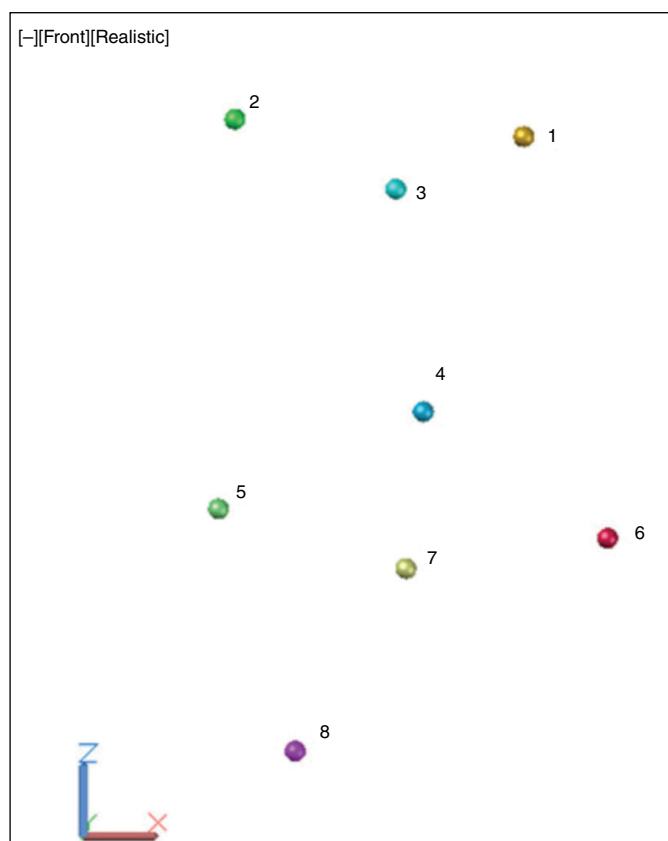

Figure 4. The estimated means for each point plotted in drawing program, the distances and angles between these points can be used to guide the passage of the screws.

RESULTS

We could not unify the data for the left and right ankles due to the topographic evaluation of the points. Thus, a guide was created for each laterality. Table 1 shows the means obtained for the positioning of each point with the confidence interval. Table 2 shows the result of the relationship between the points plotted in the drawing (Figure 3), generating the guide to perform the surgery, with expected length of the screws, distance between the points of entry of the screws and the reference points and the angles of attack of the screws. Figures 5, 6 and 7 exemplify the use of the Table 2 guide.

Table 1. The means obtained for the positioning of each point with the confidence interval.

Plane X Right Ankle	Mean	CI
Lateral Entry Point	34.78 mm	(29.97 – 39.58)
Medial Entry Point	61.46 mm	(56.25 – 66.66)
Posterior Entry Point	45.57 mm	(39.15 – 52.00)
Anterior Tibia Point	46.03 mm	(41.47 – 50.60)
Medial Malleolus Point	70.26 mm	(65.45 – 75.07)
Lateral Malleolus Point	26.80 mm	(17.15 – 36.45)
Talus Upper Point	47.98 mm	(42.98 – 53.01)
Talus Upper Point	56.309	56.309
Plane Y Right Ankle	Mean	CI
Lateral Entry Point	13.25 mm	(8.01 – 18.49)
Medial Entry Point	8.82 mm	(4.90 – 12.75)
Posterior Entry Point	19.39 mm	(1.51 – 37.28)
Anterior Tibia Point	-0.06 mm	(-3.48 – 3.35)
Medial Malleolus Point	4.46 mm	(-1.32 – 10.61)
Lateral Malleolus Point	25.81 mm	(20.42 – 31.20)
Talus Upper Point	-15.76 mm	(-18.87 – -12.64)
Talus Upper Point	-3.85 mm	3.85
Plane Z Right Ankle	Mean	CI
Lateral Entry Point	1143.86 mm	(1141.29 – 1146.42)
Medial Entry Point	1146.83 mm	(1145.42 – 1148.23)
Posterior Entry Point	1128.67 mm	(1108.43 – 1148.90)
Anterior Tibia Point	1117.26 mm	(1114.59 – 1119.92)
Medial Malleolus Point	1109.98 mm	(1106.71 – 1113.24)
Lateral Malleolus Point	1098.22 mm	(1095.95 – 1100.49)
Talus Upper Point	1102.61 mm	(1100.52 – 1104.69)
Talus Upper Point	1083.8 mm	1083.8 mm
Plane Y Left Ankle	Mean	CI
Lateral Entry Point	14.58 mm	(7.46 – 21.71)
Medial Entry Point	5.77 mm	(2.53 – 9.00)
Posterior Entry Point	27.19 mm	(22.15 – 32.22)
Anterior Tibia Point	2.44 mm	(-1.09 – 5.98)
Medial Malleolus Point	1.77 mm	(-0.9 – 4.47)
Lateral Malleolus Point	29.22 mm	(19.71 – 38.73)
Talus Upper Point	-12.26 mm	(-17.15 – -7.37)
Talus Upper Point	3.85	3.85
Plane Z Left Ankle	Mean	CI
Lateral Entry Point	1141.95 mm	(1134.99 – 1148.91)
Medial Entry Point	1143.59 mm	(1139.39 – 1147.80)
Posterior Entry Point	1136.99 mm	(1135.05 – 1138.92)
Anterior Tibia Point	1115.93 mm	(1111.35 – 1120.51)
Medial Malleolus Point	1106.72 mm	(1104.19 – 1109.24)
Lateral Malleolus Point	1103.96 mm	(1084.03 – 1123.90)
Talus Upper Point	1101.08 mm	(1099.50 – 1102.66)
Talus Upper Point	1083.8	1083.8

Table 2. Surgical guide obtained by the analysis of the correlation between the midpoints of the right ankle.

Right Ankles		
Entry Point Lateral	Superior to Medial Malleolus	4.56 cm
	Posterior to Medial Malleolus	0.79 cm
Entry Point Medial	Superior to Medial Malleolus	3.68 cm
	Posterior to Medial Malleolus	0.88 cm
Posterior Entry Point	Superior to Medial Malleolus	3.045 cm
	Posterior to Medial Malleolus	1.87 cm
Entry angle in relation to the longitudinal axis of the Tibia	17.34 degrees (for lateral and medial screws)	
Entry angle in relation to tibia axial axis	zero for lateral and medial screws	
Entry angle in relation to the longitudinal axis of the Tibia	39.05 degrees (for the posterior screw)	
Entry angle in relation to tibia axial axis	59.26 degrees (for the posterior screw)	
Length of lateral screw	4.62 cm	
Length of medial screw	4.34 cm	
Length of posterior screw	4.57 cm	
Entry Point Lateral	Superior to Medial Malleolus	3.79 cm
	Posterior to Medial Malleolus	0.79 cm
Entry Point Medial	Superior to Medial Malleolus	3.68 cm
	Posterior to Medial Malleolus	0.15 cm
Posterior Entry Point	Superior to Medial Malleolus	3.303 cm
	Posterior to Medial Malleolus	2 cm
Entry angle in relation to the longitudinal axis of the Tibia	17.34 degrees (for lateral and medial screws)	
Entry angle in relation to tibia axial axis	zero for lateral and medial screws	
Entry angle in relation to the longitudinal axis of the Tibia	38.35 degrees (for the posterior screw)	
Entry angle in relation to tibia axial axis	57.29 degrees (for the posterior screw)	
Length of lateral screw	4.33 cm	
Length of medial screw	4.48 cm	
Length of posterior screw	6.2 cm	

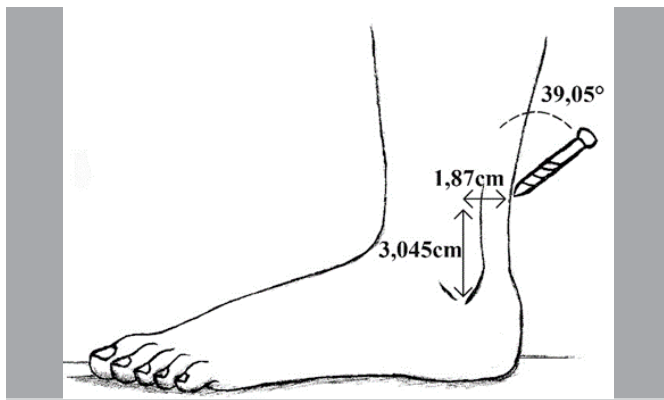

Figure 5. Application of coordinates from Table 2.

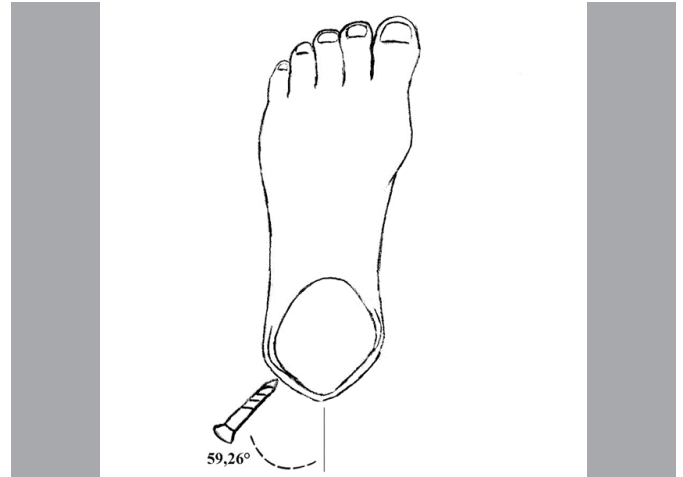

Figure 6. Application of coordinates from Table 2.

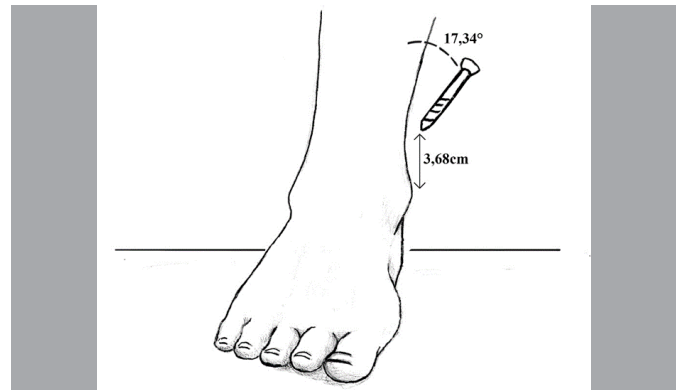

Figure 7. Application of coordinates from Table 2.

DISCUSSION

Although ankle arthrodesis is a widely performed procedure, especially because it is the only possible procedure in many cases, we could not find a description of each step based on an anatomical study.

High non-consolidation rates reported in all types of fixation make this an important issue.^{7,8,15} Many studies focus on the biomechanical stability of different fixation methods¹¹; however, they do not mention how to find the best entry point and the entry angle for the screw, which increases the need for experience and skill of the surgeon, increasing the chance of error.

The best positioning and the quantity of screws are still controversial. The two screws of the crossed coronal plane can compress at the arthrodesis site, failing, however, to stabilize the strong traction in the sagittal plane of the Achilles tendon or the dorsiflexor force made by the forefoot in the soil, which generated the need to add a third screw in the sagittal plane.^{11,20}

Despite the evidences showing that the screw of the sagittal plane should be passed from anterior to posterior¹³, we have chosen to study the method as a posterolateral "home-run" screw to the center of the talus head because it seems to be the most used method by surgeons.¹⁰

The confidence interval was very wide in most of the points analyzed, often greater than 10 cm, which is above the tolerable considering that the ankle is a small joint. Thus, our study can work as an initial orientation for surgeons. Initial statistical analysis showed that we will need 357 ct scans to develop an accurate guide to be used with all the population. This study has been developed by our group.

Despite the small sample, the two groups generated, right and left, showed similar results (angles of entry of the lateral and medial screws were 17.34° for the right and 18° to the left, for example). This suggests that the applied method is simple and reproducible. Moreover, it uses widely available computer tests and programs, generating the possibility of evaluating larger populations.

AUTHORS' CONTRIBUTION: Each author contributed individually and significantly to the development of this article: RSA: project design, development of the ct analysis technique, data compilation, writing of the article. MPBC: data compilation and tabulation, marking of points of interest in tomography. JRL: selection of appropriate tomographic cuts, adjustment of images for analysis. MPBC: data compilation and tabulation, marking of points of interest in tomography. MJDT: coordination of the project, statistical analysis and review of the article. JADL: project coordination, statistical analysis and review of the article.

REFERENCES

1. Singer S, Klejman S, Pinsker E, Houck J, Daniels T. Ankle arthroplasty and ankle arthrodesis: gait analysis compared with normal controls. *J Bone Joint Surg Am.* 2013;95(24):e191(1-10).
2. Ernesto GGD Jr, Prata SDS, Farias F, Rizzo MA. Resultados clínicos e funcionais da artrodesse tibiotársica no tratamento do pé caído. *Rev ABTPé.* 2016;10(1):1-5.
3. Vaishya R, Azizi AT, Agarwal AK, Vijay V. Arthroscopic assisted ankle arthrodesis: a retrospective study of 32 cases. *J Clin Orthop Trauma.* 2017;8(1):54-8.
4. Beliën H, Biesmans H, Steenwerckx A, Bijlens E, Dierickx C. Prebending of osteosynthesis plate using 3D printed models to treat symptomatic os acromiale and acromial fracture. *J Exp Orthop.* 2017;4(1):34-43.
5. Somberg AM, Whiteside WK, Nilssen E, Murawski D, Liu W. Biomechanical evaluation of a second generation headless compression screw for ankle arthrodesis in a cadaver model. *Foot Ankle Surg.* 2016;22(1):50-4.
6. Glazebrook MA, Holden D, Mayich J. Fibular sparing z-osteotomy technique for ankle arthrodesis. *Tech Foot Ankle Surg.* 2009;8(1):34-7.
7. Kolodziej L, Sadlik B, Sokolowski S, Bohatyrewicz A. Results of arthroscopic ankle arthrodesis with fixation using two parallel headless compression screws in a heterogenic group of patients. *Open Orthop J.* 2017;11:37-44.
8. Henricson A, Jehpsson L, Carlsson A, Rosengren BE. Re-arthrodesis after primary ankle fusion: 134/1,716 cases from the Swedish Ankle Registry. *Acta Orthop.* 2018;89(5):560-4.
9. Davies M, Blundell C. A New lateral fixed angle locking ankle arthrodesis plate: technique and rate of union. *Tech Foot Ankle Surg.* 2017;16(4):199-206.
10. Goetzmann T, Molé D, Jullion S, Roche O, Sirveaux F, Jacquot A. Influence of fixation with two vs. three screws on union of arthroscopic tibio-talar arthrodesis: comparative radiographic study of 111 cases. *Orthop Traumatol Surg Res.* 2016;102(5):651-6.
11. Gutteck N, Martin H, Hanke T, Matthies JB, Heilmann A, Kielstein H, et al. Posterolateral plate fixation with Talarlock® is more stable than screw fixation in ankle arthrodesis in a biomechanical cadaver study. *Foot Ankle Surg.* 2018;24(3):208-12.
12. Clifford C, Berg S, McCann K, Hutchinson B. A biomechanical comparison of internal fixation techniques for ankle arthrodesis. *J Foot Ankle Surg.* 2015;54(2):188-91.
13. Alonso-Vázquez A, Lauge-Pedersen H, Lidgren L, Taylor M. Initial stability of ankle arthrodesis with three-screw fixation. A finite element analysis. *Clin Biomech (Bristol, Avon).* 2004;19(7):751-9.
14. Silveira JDX, Pereira VF, Masuda VY, Azevedo RM, Mansur NSB. Preliminary outcomes of anterior ankle arthrodesis. *Sci J Foot Ankle.* 2018;12(3):173-9.
15. Prissel MA, Simpson GA, Sutphen SA, Hyer CF, Berlet GC. Ankle arthrodesis: a retrospective analysis comparing single column, locked anterior plating to crossed lag screw technique. *J Foot Ankle Surg.* 2017;56(3):453-6.
16. Willegger M, Holinka J, Nemecek E, Bock P, Wanivenhaus AH, Windhager R, Schuh R. Reliability of the radiographic sagittal and frontal tibiotalar alignment after ankle arthrodesis. *PLoS One.* 2016;11(4):e0154224.
17. Kristen KH, Trnka HJ, Wien F. Ankle arthrodesis with an anterior approach. *Tech Foot Ankle Surg.* 2007;6(4):243-8.
18. Taylor BC. Ankle arthrodesis utilizing a single lateral exposure and headless screw fixation. *Tech Foot Ankle Surg.* 2011;10(3):122-6.
19. Schuberth JM, Ruch JA, Hansen ST Jr. The tripod fixation technique for ankle arthrodesis. *J Foot Ankle Surg.* 2009;48(1):93-6.
20. Kamijo S, Kumai T, Tanaka S, Mano T, Tanaka Y. Comparison of compressive forces caused by various cannulated cancellous screws used in arthroscopic ankle arthrodesis. *J Orthop Surg Res.* 2017;12(1):7-15.

RELATIONSHIP BETWEEN QUALITY OF LIFE AND RADIOLOGICAL PARAMETERS AFTER HALLUX VALGUS CORRECTION

RELAÇÃO ENTRE A QUALIDADE DE VIDA E PARÂMETROS RADIOGRÁFICOS APÓS CORREÇÃO DO HÁLUX VALGO

HENRIQUE MANSUR^{1,2} , VINICIUS CARDOSO² , THOMAS NOGUEIRA² , ISNAR CASTRO² 

1. Universidade de Brasília, Brasília, DF, Brazil.

2. Instituto Nacional de Traumatologia e Ortopedia, Rio de Janeiro, RJ, Brazil.

ABSTRACT

Objective: To evaluate the correlation between postoperative quality of life and the severity of hallux valgus deformity. **Methods:** A total of 23 patients underwent moderate ($n = 14$) and severe ($n = 9$) hallux valgus (HV) surgical correction with the Scarf technique between January 2010 and December 2012. The mean follow-up time was 60 months. Participants answered the SF-36 quality of life assessment questionnaire and their radiographs were evaluated at three different moments (preoperative, 1 and 5 years after surgery). Statistical analysis was performed with a maximum 5% significance level. **Results:** The sample consisted of two men and 21 women, aged 58.7. SF-36 mean value was 75.73 and the metatarsophalangeal and interphalangeal angles improved significantly at the three moments ($p < 0.05$). SF-36 showed no statistical difference between patients with moderate or severe HV ($p > 0.05$). No correlations were found between quality of life and pre and postoperative radiographic angles. **Conclusion:** Patients with moderate and severe hallux valgus submitted to surgical correction had a very good quality of life and a significant improvement in radiographic parameters. However, these variables were not correlated. **Level of Evidence II, Retrospective study.**

Keywords: Hallux Valgus. Osteotomy. Quality of Life.

RESUMO

Objetivo: Avaliar a correlação entre qualidade de vida pós-operatória e a gravidade da deformidade do hálux valgo. **Métodos:** 23 pacientes foram submetidos à correção cirúrgica do hálux valgo (HV) moderado ($n = 14$) e grave ($n = 9$) pela técnica de Scarf, entre janeiro de 2010 e dezembro de 2012. O tempo mínimo de acompanhamento foi de 60 meses. Os participantes responderam ao questionário de avaliação de qualidade de vida SF-36 e foram avaliadas suas radiografias em três momentos distintos (pré-operatório, 1 e 5 anos de pós-operatório). A análise estatística foi realizada com nível de significância máximo de 5%. **Resultados:** A amostra contou com 2 homens e 21 mulheres, com média de idade 58,7 anos. O valor médio do SF-36 foi 75,73 e os ângulos metatarsofalangeal e interfalangeal apresentaram melhora significativa nos momentos avaliados ($p < 0,05$). O SF-36 não mostrou diferença estatística entre os pacientes com HV moderado ou grave ($p > 0,05$). Não houve correlações entre a qualidade de vida e os ângulos radiográficos pré e pós-operatórios. **Conclusão:** Os pacientes com hálux valgo moderado e grave submetidos à correção cirúrgica apresentaram qualidade de vida considerada muito boa e tiveram significativa melhora dos parâmetros radiográficos. Contudo, não houve associação entre essas variáveis. **Nível de Evidência II, Estudo retrospectivo.**

Descritores: Hallux Valgus. Osteotomia. Qualidade de Vida.

Citation: Mansur H, Cardoso V, Nogueira T, Castro I. Relationship between quality of life and radiological parameters after hallux valgus correction. *Acta Ortop Bras.* [online]. 2020;28(2):65-8. Available from URL: <http://www.scielo.br/aob>.

INTRODUCTION

Hallux valgus (HV) is a deformity prevalent in 23% of the adult population aged between 18 and 65 and in 35.7% of those above 65, especially women. In addition to aesthetic deformity, most patients experience pain in the first metatarsophalangeal joint, and for 30% of them, wearing footwear is difficult, which leads to worse quality of life.¹⁻⁴

Several surgical techniques are described to correct the various degrees of deformity, allowing the performance of soft tissue

balancing procedures to surgeries involving osteotomies and arthrodeses.⁴⁻⁶ Burutaran and Zygmunt originally described the Scarf technique, and Weil and Barouk later popularized it. It is a Z osteotomy to realign the first metatarsal bone, widely used to correct different degrees of HV deformity.⁷⁻¹¹

Most articles published on the topic compare the results between the different surgical techniques, evaluating the degree of radiographic correction, relapse rates and complications. Data such as pain and range of motion of the first metatarsophalangeal

All authors declare no potential conflict of interest related to this article.

The study was conducted at the Department of Foot and Ankle Surgery of Instituto Nacional de Traumatologia e Ortopedia.

Correspondence: Henrique Mansur. Área Militar do Aeroporto Internacional de Brasília, Lago Sul, Brasília, DF, 71607-900. henrimansur@globo.com

Article received on 06/22/2019, approved on 09/19/2019.



joint are commonly used by surgeons to evaluate the postoperative outcome.^{10,12} However, surgeon and patient diverge on their perception. Often, although with a residual deformity, patients are highly satisfied. SF-36 score, when evaluating the psychometric properties of the patient's quality of life, allows a broader analysis of the postoperative outcome of bunion correction surgery from the patient's point of view.¹³⁻¹⁶

Studies evaluating the quality of life of patients with hallux valgus and, mainly, relating quality of life to the degree of radiological correction are scarce.^{13,14} Thus, this work aims to evaluate the correlation between quality of life and radiographic parameters obtained after hallux valgus surgical correction using the Scarf technique. Our hypothesis is that even patients with residual radiographic deformities improve their quality of life after surgery. To know this correlation endorses the importance of the deformity clinical correction rather than of the radiographic aspect.

METHODS

This study was approved by the Institution Research Ethics Committee. A study was conducted with all patients submitted to moderate and severe HV surgical correction by Scarf technique associated with soft tissue release between January 2010 and December 2012 to obtain a cohort of patients with a minimum follow-up of five years. Different specialists from the foot and ankle surgery group of the institution performed the surgeries and all patients followed the same postoperative protocol and signed the informed consent form.

Patients without all necessary imaging tests, patients with mild deformities, those submitted to deformity correction with other techniques, revision surgeries or bilateral correction were excluded. Besides, patients who disagreed to participate in the study were removed.

Patients who met the inclusion and exclusion criteria were invited to participate in the study. The characteristics recorded were sex, age at the time of surgery and operated foot. Quality of life was quantified applying the Medical Outcomes Study 36-Item Short-Form (SF-36). The questionnaire has 36 items, divided into eight scales (physical functioning, role limitations due to physical health, pain, general health, energy/fatigue, social functioning, emotional well-being, and role limitations due to emotional problems), with scores ranging from zero (worst general health status) and 100 (best health status). The form involves aspects related to disease consequences, it has already been validated for the Portuguese language in Brazil and proved to be reliable to evaluate the results of hallux valgus correction surgery.¹⁷⁻²⁰ All participants were evaluated by the lead researcher, who did not participate in the surgery of any of them.

Radiographic analysis

Foot radiographs in orthostasis at dorsoplantar incidences and profile were performed by the patients before surgery, about one and five years after surgical correction. The radiographic parameters evaluated and compared in the three moments were the following:

- metatarsophalangeal angle (MPA)²¹: angle formed by the lines that bisect the diaphysis of the first metatarsal and of the hallux proximal phalanx;
- Intermetatarsal angle (IMA)²¹: angle formed by the lines that bisect the diaphyses of the first and second metatarsals.

Each angle was measured twice by the same examiner, with a one-week interval between the evaluations, and calculated in degrees with the angular measurement tool of the Dicom Viewer software, version 3.0.0®, in the dorsoplantar incidence with load.

The patients were separated into two groups according to radiographic parameters. The moderate hallux valgus group included patients with intermetatarsal angle between 11° and 16° or metatarsophalangeal between 20° and 40°; and the severe hallux valgus group included those with intermetatarsal angle higher than 16° or metatarsophalangeal higher than 40°, according to Couglin's criteria.^{21,22} Demographic characteristics, final values of SF-36 score, and radiographic parameters were compared between the two subpopulations.

Statistical analysis

Continuous variables were reported as mean ± standard deviation and were compared between moderate and severe HV groups and between different pre and postoperative moments. When repeated measurements of the same variable were normal, we compared two of them using the paired Student t-test and then three measurements with the ANOVA test for repeated measurements, with the post-hoc corrections of Bonferroni and Tukey to compare means. When they did not follow normal distribution, we compared two measurements with the Wilcoxon nonparametric test and three repeated measurements using the Kruskal-Wallis test. The assumption of normality for continuous variables was evaluated with the Kolmogorov-Smirnov (KS) and Shapiro-Wilk (SW) tests. The correlational research between two quantitative variables was performed by calculating the Spearman's rank-order correlation coefficient or Pearson Test. Based on the collected data, a database was built in a spreadsheet to analyze them with the IBM SPSS (Statistical Package for the Social Science) program, version 21.0, and with Microsoft Excel. All discussions considered a 5% (0.05) maximum significance level.

RESULTS

A total of 23 patients met the inclusion and exclusion criteria. Nine patients (39.1%) had severe HV and 14 (60.9%), moderate HV. Of the patients with severe HV, six had MPA > 40° and three had IMA higher than 16°. The patients' mean age at the time of surgery was 58.7 ± 8.99 (39-76 year-olds), 57.4 in the severe group, and 59.5 in the moderate group. This result showed no statistical difference (p > 0.05) (Table 1).

Table 1. Baseline characteristics of the total sample and per subgroup.

	Mean	Max	Min	SD	Moderate HV	Severe HV
Sample	total (n = 23)				n = 14	n = 9
Sex	13W 11M				16W 0M	7W 2M
Side	12R 12L				10R 4L	5R 4L
Age	58.7	76	39	8.99	59.5	57.4
SF-36	75.7	91	33.4	15.77	73.3	79.5

HV: hallux valgus; SD: standard deviation; W: women; M: men; R: right; L: left.

After a 60-month minimum follow-up time, the total sample SF-36 was 75.7 (SD ± 15.77) and per subgroup it was 79.5 and 73.3, respectively for severe and moderate HV. This difference had no statistical significance (p > 0.05).

The values found when measuring the metatarsophalangeal angle in the preoperative phase, one and five years after surgery, showed significant improvement (p < 0.05) in all three moments. Regarding the intermetatarsal angle, the initial values improved considerably one year after surgery and these values also improved after five years (p < 0.05). However, the difference between the initial values and after five years was insignificant (p > 0.05) (Table 2 and Figure 1).

Table 2. Variation of radiographic parameters in the pre and postoperative period of patients submitted to HV correction with the Scarf technique.

	Mean	Max	Min	SD	Moderate HV	Severe HV
MPA	33.9	50	20	8.62	28.5	42.4
MPA1	13.9	26	2	6.19	12	16.9
MPA5	18.5	41	2	8.90	17.4	20.2
IMA	14.8	19	6	3.00	13.4	17.1
IMA1, 2011	7.7	14	2	2.95	6.8	9.1
IMA5	8.8	14	2	3.27	8.4	9.4

Caption: HV: hallux valgus; SD: standard deviation; MPA: metatarsal angle; MPA1: one year after surgery; MPA5: five years after surgery; IMA: intermetatarsal angle.

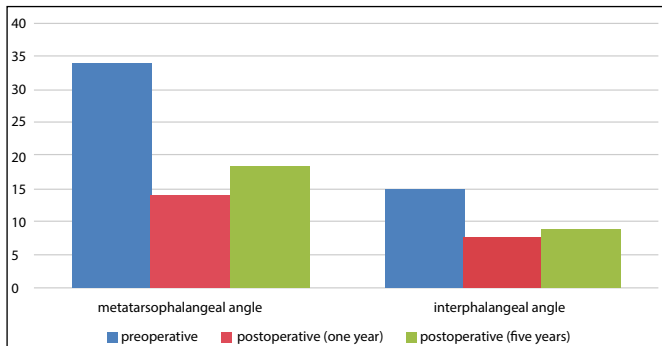

Figure 1. Pre and postoperative radiographic parameters to HV correction with the Scarf technique.

The quality of life (SF-36) of patients five years after surgery and the values of radiographic parameters (MPA and IMA) preoperatively, one and five years after surgery ($p > 0.05$) were not correlated. Similarly, SF-36 and the patients' age at the time of surgery were not correlated ($p > 0.05$).

DISCUSSION

This study aimed to determine the correlation between quality of life (QoL) and radiographic parameters after Scarf surgery for HV correction. Our initial hypothesis has been confirmed. We found no correlation between the SF-36 values and the radiographic parameters measured in the late postoperative period. In addition, no differences in QoL were found between patients who had moderate and severe deformities. Our findings serve for surgeons to care more about clinical criteria than radiographic when evaluating their postoperative results.

Scarf technique is widely used especially for moderate to severe deformities, presenting great correction power.^{7,10,23,24} Our patients' metatarsophalangeal and interphalangeal angles improved

significantly. MPA was significantly lower ($p < 0.05$) than the preoperative period at all postoperative moments; IMA has improved significantly after one year ($p < 0.05$), which remained improving after five years, but without relevance ($p > 0.05$). Accordingly, Choi et al.²³ evaluated 53 feet operated with the technique and all radiographic changes showed statistically significant improvement. The difference is that these authors had a 24-month mean follow-up, while in this study it was 60 months.

The SF-36 score sum in our work showed a mean value of 75.7 points, with no statistical difference ($p > 0.05$) between the groups of patients with moderate and severe hallux valgus. According to the Spanish version of SF-36, adapted by Caporicci and Neto,²⁵ the final score was divided into: 0 = Bad; from 0 to 25 = Regular; from 26 to 61 = Good; from 62 to 84 = Very Good, and from 85 to 100 = Excellent. Thus, we can consider that after the mean time of five years, the operated patients' quality of life was very good.^{17,21} Menz et al.¹⁹ evaluated patients with hallux valgus and compared clinical deformity and QoL with SF-36. They found a reduction in QoL when deformity worsened. Lopez et al.²⁶, after evaluating 100 women with HV, confirmed a relationship between QoL and the bunion deformity. However, these authors used the Manchester scale to measure foot deformity, while our study used objective angular parameters measured on radiographs. In accordance with our results, other authors^{27,28} found no relationship between the degree of radiographic deformity and the score obtained in the SF-36, proving the relevance of SF-36 to evaluate the results of hallux valgus surgeries. We can see a correlation between worse quality of life and HV deformity when it is clinically analyzed. It is different when we consider radiographic parameters; however, literature has no consensus. Lazarides et al.²⁹, preoperatively evaluating radiographs of 22 patients together with SF-36, attested the more severe the deformity, the worse the QoL.

Our study has some limitations, such as sample size, although it is compatible with the number of patients in other studies. In addition, the SF-36 evaluation at one single moment limited us in identifying changes in the patients' quality of life in an evolutionary way. The studies on the subject show hallux valgus cripples QoL when clinical criteria based on patients' impressions are analyzed. On the other hand, articles that use angular measurement in their methodology report no relationship between deformity and QoL. Although this was not the objective of our work, we infer that sometimes HV hypocorrection aiming at a better aesthetic result, especially in more severe cases, can bring more satisfactory results to the patient.

CONCLUSION

The quality of life of patients submitted to the Scarf technique for moderate and severe hallux valgus correction has no correlation with postoperative radiographic parameters after five years of surgery.

AUTHORS' CONTRIBUTION: Each author contributed individually and significantly to the development of this article. HM: writing and review of the article and approval of the final version; VC: idealization and planning of the activities that led to the study, writing of the article and approval of the final version; TN: writing and review of the article and approval of the final version; IC: text review and approval of the final version.

REFERENCES

- Menz HB, Lord SR. Gait instability in older people with hallux valgus. *Foot Ankle Int.* 2005;26(6):483-9.
- Roddy E, Zhang W, Doherty M. Prevalence and associations of hallux valgus in a primary care population. *Arthritis Rheum.* 2008;59(6):857-62.
- Nix S, Smith M, Vicenzino B. Prevalence of hallux valgus in the general population: a systematic review and meta-analysis. *J Foot Ankle Res.* 2010;3:21.
- Robinson AH, Limbers JP. Modern concepts in the treatment of hallux valgus. *J Bone Joint Surg Br.* 2005;87(8):1038-45.
- López DL, Callejo González L, Losa Iglesias ME, Canosa JLS, Sanz DR, Lobo CC, Vallejo RBB. Quality of life impact related to foot health in a sample of older people with hallux valgus. *Aging Dis.* 2016;7(1):45-52.
- Okuda R, Kinoshita M, Yasuda T, Jotoku T, Kitano N, Shima H. The shape of the lateral edge of the first metatarsal head as a risk factor for recurrence of hallux valgus. *J Bone Joint Surg Am.* 2007;89(10):2163-72.
- Molloy A, Widnall J. Scarf osteotomy. *Foot Ankle Clin.* 2014;19(2):165-80.

8. Burutaran JM. Hallux valgus y cortedad anatomica del primer metatarsano (correction quirurgica). *Actual Med Chir Pied.* 1976;XIII:261-6.
9. Zygmunt KH, Gudas CJ, Laros GS. Z-bunionectomy with internal screw fixation. *J Am Podiatr Med Assoc.* 1989;79(7):322-9.
10. Borrelli AH, Weil LS. Modified scarf bunionectomy: our experience in more than 1000 cases. *J Foot Surg.* 1991;30:609-12.
11. Barouk LS. Scarf osteotomy of the first metatarsal in the treatment of hallux valgus. *Foot Dis.* 1991;2:35-48.
12. Thordarson DB, Rudicel SA, Ebramzadeh E, Gill LH. Outcome study of hallux valgus surgery-an AOFAS multi-center study. *Foot Ankle Int.* 2011;22(12):956-9.
13. Cardoso VT, Mansur H, Castro IM Jr. Avaliação da qualidade de vida e parâmetros radiológicos após a correção do hálux valgo. *Sci J Foot Ankle.* 2019;13(1):3-9.
14. Klugarova J, Hood V, Bath-Hextall F, Klugar M, Mareckova J, Kelnarova Z. Effectiveness of surgery for adults with hallux valgus deformity: a systematic review. *JBI Database System Rev Implement Rep.* 2017;15(6):1671-710.
15. Baumhauer JF, McIntosh S, Rehtine G. Age and sex differences between patient and physician-derived outcome measures in the foot and ankle. *J Bone Joint Surg Am.* 2013;95(3):209-14.
16. Schneider W, Knahr K. Surgery for hallux valgus. The expectations of patients and surgeons. *Int Orthop.* 2001;25(6):382-5.
17. Ciconelli RM, Ferraz MB, Santos W, Meinão I, Quaresma MR. Tradução para a língua portuguesa e validação do questionário genérico de avaliação de qualidade de vida SF-36. A reliable and valid quality of life outcome measure. *Rev Bras Reumatol.* 1999;39(3):143-50.
18. Saro C, Jensen I, Lindgren U, Felländer-Tsai L. Quality-of-life outcome after hallux valgus surgery. *Qual Life Res.* 2007;16(5):731-8.
19. Menz, HB, Roddy E, Thomas E, Croft PR. Impact of hallux valgus severity on general and foot and foot-specific health-related quality of life. *Arthritis Care Res (Hoboken).* 2011;63(3):396-404.
20. Chen L, Lyman S, Do H, Karlsson J, Adam SP, Young E, et al. Validation of foot and ankle outcome score for hallux valgus. *Foot Ankle Int.* 2012;33(12):1145-55.
21. Coughlin MJ. Hallux valgus. *J Bone Joint Surg Am.* 1996;78(6):932-66.
22. Costa MT, Pinto RZA, Ferreira RC, Sakata MA, Frizzo GG, Santin RAL. Osteotomia da base do I metatarsal no tratamento do hálux valgo moderado e grave: resultados após seguimento médio de oito anos. *Rev Bras Ortop.* 2009;44(3):247-53.
23. Choi JH, Zide JR, Coleman SC, Brodsky JW. Prospective study of the treatment of adult primary hallux valgus with scarf osteotomy and soft tissue realignment. *Foot Ankle Int.* 2013;34(5):684-90.
24. Ma Q, Liang X, Lu J. Chevron osteotomy versus scarf osteotomy for hallux valgus correction: a meta-analysis. *Foot Ankle Surg.* 2018;pii:S1268-7731(18)30418-1.
25. Caporicci S, Neto MFO. Estudo comparativo de idosos ativos e inativos através da avaliação das atividades da vida diária e medição da qualidade de vida. *Motri.* 2011;7(2):15-24.
26. Palomo-López P, Becerro-de-Bengoa-Vallejo R, Losa-Iglesias ME, Rodríguez-Sanz D, Calvo-Lobo C, López-López D. Impact of hallux valgus related of quality of life in women. *Int Wound J.* 2017;14(5):782-5.
27. Thordarson DB, Ebramzadeh E, Rudicel SA, Baxter A. Age-adjusted baseline data for women with hallux valgus undergoing corrective surgery. *J Bone Joint Surg Am.* 2005;87(1):66-75.
28. Saro C, Jensen I, Lindgren U, Felländer-Tsai L. Quality-of-life outcome after hallux valgus surgery. *Qual Life Res.* 2007;16(5):731-8.
29. Lazarides SP, Hildreth A, Prassanna V, Talkhani I. Association amongst angular deformities in hallux valgus and impact of the deformity in health-related quality of life. *Foot Ankle Surg.* 2005;11(4):193-6.

MEASUREMENT OF PELVIC RETROVERSION DURING HIP FLEXION: EVALUATION WITH ACCELEROMETERS

MENSURAÇÃO DE RETROVERSÃO PÉLVICA DURANTE FLEXÃO DO QUADRIL: AVALIAÇÃO COM ACELERÔMETROS

ALEXANDRE JUNIOR FENATO^{1,2} , LARISSA MARTINS GARCIA³ , GLEICI DA SILVA CASTRO PERDONÁ⁴ , DANIEL AUGUSTO MARANHO² 

1. Universidade Tecnológica Federal do Paraná, Electronic Engineering Department, Campus de Ponta Grossa, PR, Brazil.

2. Universidade de São Paulo, Medical School of Ribeirão Preto, Graduate Program in Health Applied Sciences to the Locomotor System, Ribeirão Preto, SP, Brazil.

3. Universidade de São Paulo, Hospital das Clínicas of the Medical School of Ribeirão Preto, Ribeirão Preto, SP, Brazil.

4. Universidade de São Paulo, Medical School of Ribeirão Preto, Social Medicine Department, Ribeirão Preto, SP, Brazil.

ABSTRACT

Objective: To quantify pelvic retroversion during clinical evaluation of hip flexion with accelerometers and to verify the reliability of these sensors to measure hip flexion. **Methods:** An accelerometer was positioned laterally in the pelvis to measure pelvic retroversion. Another accelerometer was positioned anteriorly on the thigh to evaluate hip flexion amplitude. The evaluations were performed with volunteers in supine position by three raters. For evaluation of pelvic retroversion, the mean \pm SD (minimum-maximum) was calculated. Reliability of the accelerometer between raters was determined by intraclass correlation coefficients (ICC). The linear correlation coefficient between hip flexion was determined by using goniometer and accelerometer. **Results:** The mean pelvic retroversion was $7.3^\circ \pm 0.93^\circ$ (6° - 11°) in the clinical limit of the hip range of motion, which was $106.25^\circ \pm 10.46^\circ$ (93° - 130°). The ICC between two raters were 0.60, 0.71 and 0.74 (goniometer) and 0.46, 0.71 and 0.83 (accelerometer). The linear correlation between hip flexion measurements with goniometer and accelerometer was 0.87. **Conclusion:** During clinical evaluation of the final range of hip flexion, there was an associated pelvic movement of approximately 7.3° . Accelerometers have proven to be reliable for measurement of hip flexion. **Level of Evidence III, Study of nonconsecutive patients with no gold reference standard applied uniformly.**

Keywords: Pelvis. Hip. Articular Arthrometry. Accelerometer.

RESUMO

Objetivo: Quantificar a retroversão pélvica durante avaliação clínica da flexão do quadril com acelerômetros e verificar a confiabilidade destes sensores para mensurar flexão do quadril. **Métodos:** Posicionou-se um acelerômetro lateralmente na pelve para mensurar retroversão pélvica. Outro foi posicionado anteriormente sobre a coxa para avaliar flexão do quadril. As avaliações foram realizadas com voluntários, em decúbito dorsal, por três avaliadores. Para avaliação da retroversão pélvica, determinou-se a média \pm DP (mínimo-máximo). Avaliou-se a confiabilidade dos acelerômetros entre avaliadores pelo coeficiente de correlação intraclassa (CCI). Determinou-se o coeficiente de correlação linear entre as mensurações de flexão do quadril com goniômetro e acelerômetro. **Resultados:** A retroversão pélvica média foi de $7,3^\circ \pm 0,93^\circ$ (6° - 11°), mensurada no limite clínico da flexão do quadril, que foi de $106,25^\circ \pm 10,46^\circ$ (93° - 130°), ambos com acelerômetro. Os CCI entre dois avaliadores diferentes nas avaliações de flexão do quadril foram de 0,60, 0,71 e 0,74 (goniômetro) e 0,46, 0,71 e 0,83 (acelerômetro). A correlação linear entre as mensurações de flexão do quadril com goniômetro e acelerômetro foi de 0,87. **Conclusão:** Durante avaliação clínica da amplitude final de flexão do quadril, houve movimentação associada da pelve aproximadamente de $7,3^\circ$. Acelerômetros mostraram-se confiáveis para mensuração da flexão do quadril. **Nível de evidência III, Estudo de pacientes não consecutivos sem padrão de referência "ouro" aplicado uniformemente.**

Descritores: Pelve. Quadril. Goniometria articular. Acelerômetro.

Citation: Fenato AJ, Garcia LM, Perdoná GSC, Maranhão DA. Measurement of pelvic retroversion during hip flexion: evaluation with accelerometers. *Acta Ortop Bras.* [online]. 2020;28(2):69-73. Available from URL: <http://www.scielo.br/aob>.

INTRODUCTION

The assessment of hip flexion is essential in semiology for diagnosis, rehabilitation and evolutionary follow-up of joint diseases.^{1,2} The hip flexion, osteoarthritis limitations³, femoroacetabular impingement (FAI)² and degenerative diseases of the lumbar spine are directly related.⁴

It is essential that hip flexion assessment are reliable for joint motion to ensure specific treatments, according to the biomechanical conditions of each patient.⁵

Pelvic retroversion occurs during hip flexion⁶, which can start with only 8° of hip flexion.⁷ If the retroversion of the pelvis is not properly measured, the flexion movement may be overestimated.⁸ Studies that

All authors declare no potential conflict of interest related to this article.

The study was developed at Hospital das Clínicas of Ribeirão Preto Medical School of the Universidade de São Paulo.

Correspondence: Alexandre Junior Fenato. Av. Bandeirantes, 3900, Laboratório de Bioengenharia da FMRP/USP, Ribeirão Preto, Brazil, 14015130. alefenato@usp.br



passively evaluated healthy hip mobility present variations of up to 24% in flexion results, but pelvic movement was not analyzed alone.^{9,10} Hip movement assessments in the sagittal plane are complex due to biases related to pelvis control.¹¹ Recently, an evaluative study on hip flexion with 100 healthy adults showed that pelvic retroversion of 15° occurs within the clinical limit of hip flexion amplitude.⁵

The universal goniometer (UG) is often used in hip flexion evaluation¹², but there may be difficulties during the stabilization of the anatomical segment due to the use of both hands in the handling of the goniometer arms. Furthermore, the alignment of the arms is visual and subjective.^{13,14} New tools have been used in the assessment of joint range of motion to make the process simpler and more accurate, such as: inclinometers^{15,16}, smartphone apps¹⁷, photogrammetry¹⁸, image tests¹⁹ and the Inertial Movement Unit (IMU).²⁰ Recent studies on the assessment of human gait have shown that IMU – motion sensor typically composed of acceleration transducers (accelerometers), rotation (gyroscopes) and magnetic orientation (magnetometers) –, present accurate results in kinematic knee and hip evaluations.²¹ IMU dispense external references.²⁰ In this case, after positioning the sensors, the rater's hands are free, which could enable a more accurate evaluation, including the pelvis monitoring. Quantitative data on pelvis retroversion during hip flexion evaluations are uncommon in the literature, as well as possible effects on the clinical implications of hip flexion oversizing. This study proposes the use of accelerometers to measure pelvic retroversion during clinical evaluations of hip flexion and to evaluate the reliability of these sensors to measure hip flexion movements.

MATERIAL AND METHODS

This study was approved by the Research Ethics Committee of the Institution with the consent form signed by each volunteer. A total of twenty-three hips (11 right and 12 left) of 12 volunteers (5 men and 7 women) with a mean age of 30 ± 8 years and body mass index with a median of 23.7 Kg/m² (22-27.8) were evaluated. Volunteers were healthy people with no complaints of pain, no diagnosis of disease nor hip surgery, except for a volunteer who complained of right hip pain without a defined diagnosis. He was evaluated only on the left side. Measurements were performed by three different raters – an orthopedic surgeon with 12 years of experience in hip preserving surgery, a physical therapist trained in hip physical evaluation with 10 years of experience, and an engineer involved in the development of the system with accelerometers, who received specific training for hip goniometry. A training session between raters was performed before the collection, to standardize the evaluation and the positioning of the sensors. Volunteers were asked to wear adequate clothing and to provide no resistance to performing movements. Initially, the hip flexion amplitude was evaluated in supine horizontal position by digital goniometry^{22,23}, it was followed by the evaluation of hip flexion amplitude and pelvis retroversion by the system with accelerometers. Each rater examined the hips independently, without knowing the results of the other raters. The amplitude of passive flexion was measured until the rater's perception of pelvic motion onset. Goniometry was performed with a digital device of two long arms (Brand: Vktech; Model: X15-33) (Figure 1).

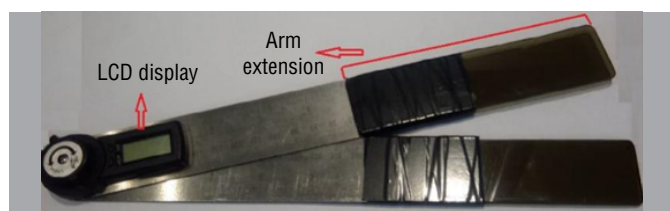

Figure 1. Digital goniometer of long arms.

The system of electronic evaluation by accelerometers was based on the Arduino platform (system with low-cost data acquisition and free software) and it was composed of two IMU (Movement Processing Unit [MPU] 6050 from Invensense), Arduino UNO acquisition plate and secondary components for connections and sampling of the data (Figure 2).

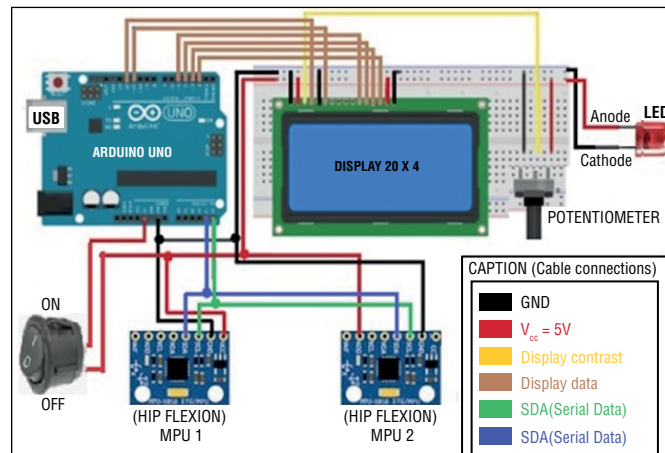

Figure 2. Electronic system for hip flexion and pelvic retroversion evaluation .

The MPUs-6050 were placed inside acrylic casings (parallelepiped format). The sensor circuit was electrically and mechanically isolated and it caused no discomfort to volunteers. Each MPU-6050 has a triaxial accelerometer (responsible for measurements), whose axes (x, y, z) were fixed parallel to the faces of the casing, with external identification of the respective orientations (Figure 3). The system worked with electrical voltages up to 5 volts, which did not provide risk of electric shocks.

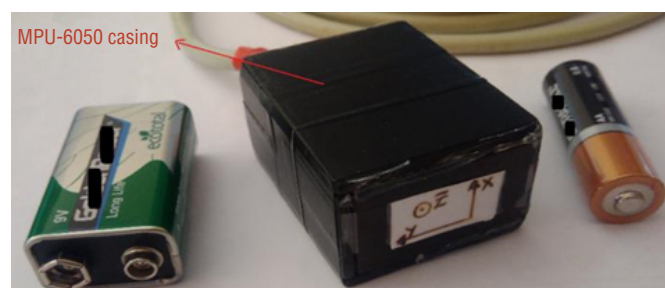

Figure 3. Casing of the hip flexion accelerometer estimator (similar to pelvic retroversion estimator) with identification of the orientations of the accelerometer axes for guidance during positioning. The batteries are for dimensional references.

The accelerometer responsible for measuring hip flexion was positioned with elastic and Velcro-like in the distal third of the thigh. The accelerometer – adjusted to measure the pelvic retroversion – was fixed laterally at the level of the anterior superior iliac spines, on the skin and under elastic firmly tied up around the pelvis (Figure 4). Both measured movements occur in the sagittal anatomical plane, with accelerometers configured to measure the variations in the gravitational acceleration (g). The three piezoelectric “membranes,” spatial and orthogonally arranged among each other in triaxial accelerometers, varying their deformations and responses according to the vector “g” (module, direction and gravitational acceleration direction).²³

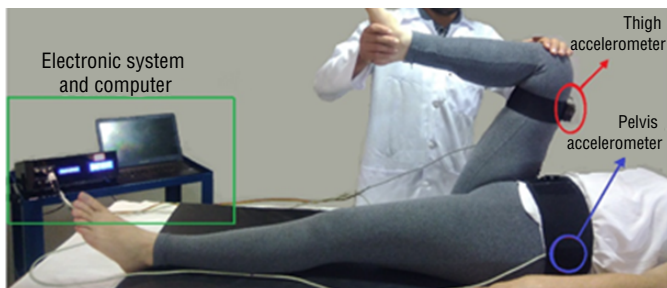

Figure 4. Positioning of pelvic accelerometers (pelvic retroversion estimator) and thigh accelerometer (hip flexion estimator).

The thigh accelerometer was placed with the “x” axis aligned to the craniocaudal axis, “y” axis on the transversal axis and the “z” axis on the anterior posterior axis, then “x,” “y,” and “z” axes are orthogonal to each other. The axes “x” and “z” vary their inclination in the sagittal plane and in relation to the vector “g,” during hip flexion movements (Figure 5). The linearity of the sensor response (proportionality relationship between deformation of piezoelectric material and measured angle) is desirable in this application and it occurs as more aligned (parallel) the axis responsible for measurement is to the vector “g.” As the flexion amplitudes usually range between 90° and 120°,²⁴ the “z” axis was more appropriate. At 90°, for example, the accelerometer will present the maximum value, because the piezoelectric material will present the greatest deformation. In the initial position (extended hip), the “z” axis has direction opposite to the vector “g.” The result is negative (deformation in the opposite direction to the “z” axis) for angles less than 90° and the result is positive (deformation and vector “g” in the same direction) for angles greater than 90° (Figure 6).

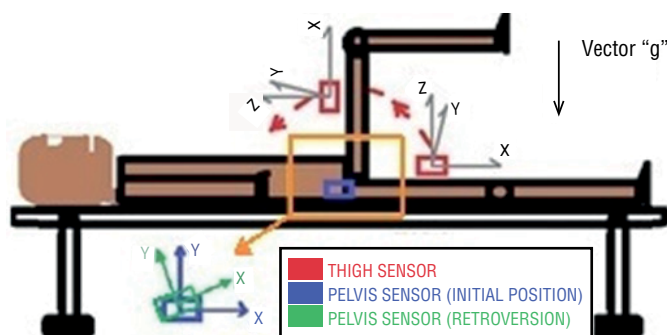

Figure 5. Lateral view of the estimator axes positioning of the pelvis and hip accelerometers. Orange rectangle: magnification of the “x” and “y” axes of the pelvis sensor in the initial position.

FLEXION ANGLE	0°	<90°	90°	>90°
RESULT SIGN	NULL	-	- ou +	+

Figure 6. Deformations of the piezoelectric material corresponding to the variation of the vector “g” position.

The determination of the axis responsible for measuring pelvic retroversion was based on the same criteria used to choose the “z” axis of the thigh accelerometer, but with positioning of the “x” and “y”

axes dependent on the inclination in the sagittal plane related to the vector “g.” The “x” axis was chosen as responsible for the retroversion measurements, because as the inclination of the axes presents small variations during this movement, the “y” axis always remains close to the parallel position in relation to the “g” vector, where the results are outside the linear accelerometer response range. The “z” (hip) and “x” (pelvis) axes chosen presents average standard error for angular measurement of 1.26° and 0.11°, respectively. The standard error was determined through the quotient of the standard deviation by the square root of the sample size. The estimator axes evaluated only inclination variations in the sagittal plane. During hip flexion evaluations, simultaneous movements (abduction or induction and internal or external rotation) of small amplitude may occur, which do not affect measurements in the sagittal plane. The results of the evaluations using the goniometer and accelerometers were noted in a specific form.

The statistical analysis of the data was assisted by the software RCrAn (R Development Core Team, R: A Language and Environment for Statistical Computing). The mean ± standard deviation (minimum and maximum value) of the results related to pelvic retroversion measurements by the three raters (69 samples) were determined. Fixed hip flexion angles (flexing angle of the pelvic retroversion subtracted of the hip angle) were estimated. The behavior of hip flexion angles was observed by a box plot graph, before (with goniometer) and after deductions from pelvis movements (with accelerometers), for the complete sample (data from the three raters). The inter-rater ICCs (for the three possible combinations of two raters) were calculated for goniometer and accelerometer to compare the measurements among raters. Pearson’s linear correlation coefficient (*r*) was determined between hip flexion measurements with goniometer and accelerometer (without pelvic retroversion deductions).

RESULTS

The values (mean ± standard deviation [minimum-maximum]) of hip flexion (goniometer), hip flexion (accelerometer), pelvic retroversion (accelerometer) and hip flexion with deduction of pelvic retroversion (accelerometers) were, respectively: 106.83° ± 8.91° (92°-129°), 106.25° ± 10.45° (93°-130°), 7.30° ± 0.93° (6°-11°) and 98.94° ± 10.27° (87°-122°). Boxplot graphs compared the behavior between hip flexion measured with goniometer and the hip flexion with deduction of pelvic retroversion measured by accelerometers (Figure 7).

The ICC estimated between two raters presented better results between physical therapist and orthopedist, for both measurement tools (Table 1). The linear correlation coefficient (*r*) between hip flexion measurements with goniometer and accelerometer was 87% (CI = 95% and *p* < 0.0001) (Figure 8).

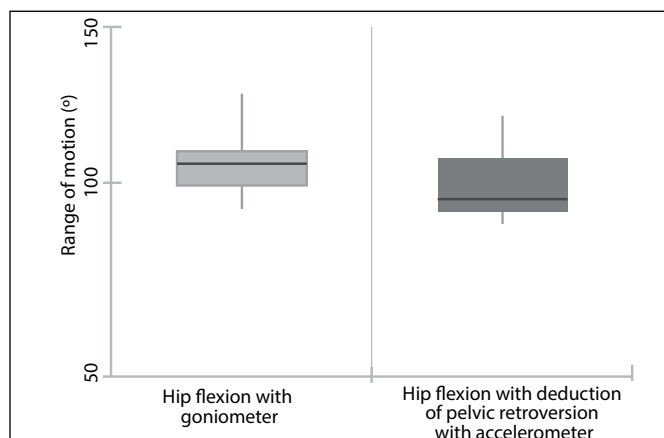

Figure 7. Box plot to compare hip flexion before (with goniometer) and after pelvic retroversion deduction (with accelerometers).

Table 1. Correlation coefficients between two different raters.

	ICC _{goniometer}	95% = CI	ICC _{accelerometer}	95% = CI
Rater 1 vs. Rater 2	0.598	-0.313–0.865	0.461	-0.299–0.78
Rater 1 vs. Rater 3	0.714	0.024–0.898	0.711	0.091–0.892
Rater 2 vs. Rater 3	0.738	0.392–0.888	0.825	0.577–0.926

Rater 1: engineer; Rater 2: hip specialist; Rater 3: Physical therapist; ICC: intraclass correlation coefficient; CI: confidence interval.

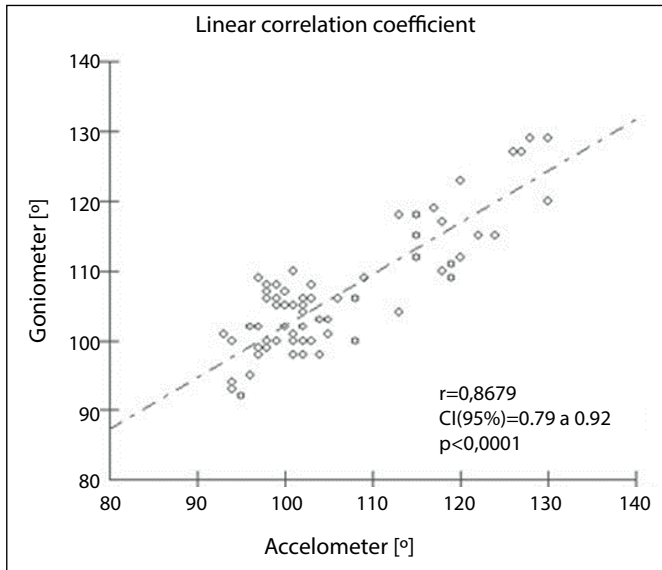

Figure 8. Graph of the linear correlation between hip flexion measurements with goniometer and accelerometer (no deductions from pelvic movements).

DISCUSSION

Hip flexion assessment is part of the classical semiology for arthrosis diagnostic², femoroacetabular impingement³, and lumbar dysfunctions⁴, in addition to specific research protocols. The more reliable the clinical interpretation of joint mobility, the more specific and effective will be the performance of the health professional. In hip flexion assessments, it is suggested the use of one hand under the pelvis to stabilize and to monitor the onset of the pelvic movement.²⁵ However, the goniometer requires both hands of the rater to be used, which hinders pelvis monitoring, a factor that implies probable overestimation of hip flexion amplitude.²¹⁻²⁸ This study presented hip flexion of approximately 107° with goniometer and 106° with accelerometer. Although the UG is considered a gold standard in evaluations of joint range of motion, it presents significant differences for hip flexion (113°-141°).^{10,16-19} New measurement instruments such as accelerometers, which do not rely on external references, would enable hip assessments with pelvic monitoring in a simple way. This study measured pelvis retroversion during hip flexion evaluations by accelerometers and obtained an average result near to 7.3°, in the sample evaluated. Hip flexion measurements performed with accelerometer and goniometer showed a strong linear correlation ($r = 0.87$). The accelerometers were reliable in the measurements of hip flexion (combined: hip plus pelvis). In most analyses, the results showed substantial or optimal inter-rater agreement ($ICC > 0.60$).²⁶ The use of accelerometers in both measurements (flexion and retroversion) proved to be simple and fast. The results regarding the pelvis retroversion increase information to the health professional, supporting the correct interpretations about the mobility of the hip joint. Clinical evaluations of hip flexion amplitude with accelerometers have the potential advantage of deducing pelvic retroversion.

Studies correlating the measurements of joint range of motion between goniometer and other instrument (inclinometers^{15,16}, smartphones¹⁷, imaging exams¹⁹, and IMU²⁰) have shown good results. With increasing technological advances in electronic and computer instrumentation, new devices and techniques are continuously available, with a tendency to improve the accuracy and versatility of the new procedures. In 2015, a study obtained excellent results in hip flexion amplitude evaluations in 20 volunteers, when it compared the measurements performed by inclinometer ($ICC = 0.94$) and smartphone ($ICC = 0.92$) with 3DMA (Three Dimensional Motion Analysis).¹¹ The high versatility and low cost of accelerometers have supported its progressive use in human gait assessments, energy expenditure monitoring and various applications in many sports.^{20,21} The good results of our research corroborate with recent studies assessing the reliability of accelerometers in human movements.^{20,21} The results presented better agreements among the raters of the field of health, especially the lower limits of the confidence interval (Table 1). A possible interpretation of this episode is due to the small experience of the first examiner (engineer) in executing the movement. Pelvic retroversion begins with approximately 8° of hip flexion and this movement is extremely complex to monitor and to quantify without technological assistance.⁷ If the retroversion of the pelvis is not considered, hip flexion can be overestimated, making the clinical interpretation inconsistent with the real mobility of the joint. In patients with FAI, during the impingement test (combination of flexion, adduction and internal rotation of the hip), the range of motions are visually assessed and vary with the combination of pelvic movements.² Without deduction of pelvic movements, patients who present normal evaluation for hip flexion may receive the FAI characteristic by lumbar compensation, which may be associated with degenerative changes in the spine.⁴ Pelvic retroversion measured in this study may be clinically important in these cases (FAI and lumbar problems) and extremely useful in decision-threshold circumstances about total hip arthroplasty and positioning guidelines of surgical prostheses. The pair of box plot graphs (Figure 7) showed reductions in median, quartiles, maximum and minimum values of the amplitudes of results of the hip flexion with deduction of pelvic retroversion (accelerometers) in relation to hip flexion without retroversion deduction (goniometer). The same graph (Figure 7) showed greater dispersion (variability) of hip flexion after deduction of pelvic movements. Several studies radiographically evaluated the spinopelvic alignment and inclination of the pelvis in the sagittal plane, with a strong linear correlation between the dimensions evaluated of the obturator foramen and the spinopelvic alignment. However, few studies quantified pelvic movements by the method.²⁷ A study composed of 101 preoperative patients of total hip arthroplasty measured – by computed tomography through the obturator foramen – the pelvic inclination in the sagittal plane and obtained 5° (degrees) of pelvic anteversion in the supine position, 3° in the upright vertical position and 29° pelvic retroversion with the patients seated.²⁸ In the aforementioned study, most patients had advanced arthrosis²⁸, which makes it impossible to use the results as parameters in researches with healthy people. Other studies have used the palpation method to identify anterior and posterior reference points of the pelvis for inclinometer fixation and pelvic anteversion measurement, whose values varied (3° to 10.3°).^{27,29}

In 2018, a study with a purpose similar to our research, measured with inclinometer the retroversion of the pelvis (15° on average) during hip flexion. At first, this evaluation occurred with patients in upright vertical position to measure pelvic anteversion (hip in neutral position). Then, in a supine position, for pelvic retroversion evaluation (at the physiological limit of flexion movement). The sum of the two results composed the total pelvic retroversion.⁵ Pelvic retroversion amplitude found in our study is lower (7.3°), compared to those found with inclinometer in 2018 (15°)⁵, justifiable differences due to the different evaluation protocols, instruments and experience of raters, especially in relation to pelvic monitoring. The hip flexion values found were also greater in the inclinometer study (116°), greater in 10° compared with this study (106°). Part of this difference probably occurred due to the different criteria regarding the final limits of movement, or variations between the populations studied. The closer to the clinical limits of flexion, the greater the tendency to occur retroversion of the pelvis, possibly as a response to the ligament and musculotendinous limits as well as to the proximity of the proximal region of the femur with the acetabular notch.

This study presented several limitations. One of the main limitations refers to the possibility of relative movement of the accelerometer positioned in the pelvis in relation to the skin and the pelvis. This factor could imply errors in the measurements. No study was found

evaluating the relative movement between pelvis and accelerometer. Another limitation refers to the lack of imaging exams, which would enable comparative evaluations, raising the reliability of the study and minimizing the hypothesis of possible evaluations in hips with pathological limitations, which could not be separated in the results. Furthermore, during the study sampling biases occurred, reducing the representativeness of the study: (a) small sample size, which did not enable to correlate variables such as sex and age group; (b) selection of volunteers for convenience. Despite the biases presented, the accelerometer has shown itself as a functional and reliable tool for semiology measurements of hip flexion and according to the positioning methodology presented, the accelerometer has the potential to measure the movements of pelvic retroversion.

CONCLUSION

The pelvic retroversion range in this study presented an approximate mean value of 7.3° . In the sample assessed, the accelerometers were reliable in hip flexion evaluations.

ACKNOWLEDGMENTS

This study was funded by the Coordination for the Improvement of Higher Education Personnel – Brazil (Capes) – Funding code 001.

AUTHORS' CONTRIBUTIONS: Each author contributed individually and significantly to the development of this article: AJF and DAM actively participated in the development of the accelerometer system and were field raters during the research; LMG was a field rater during the study; GSCP contributed significantly with statistical analysis of the work. All authors contributed throughout the intellectual concept of the article and in the preparing of the manuscript. All authors agree to be held accountable for all aspects of the work, in order to ensure that any issue related to the integrity or accuracy of any of their parties is properly investigated and resolved.

REFERENCES

1. Yuan BJ, Bartelt RB, Levy BA, Bond JR, Trousdale RT, Sierra RJ. Decreased range of motion is associated with structural hip deformity in asymptomatic adolescent athletes. *Am J Sports Med.* 2013;41(7):1519-25.
2. Diamond LE, Dobson FL, Bennell KL, Wrigley TV, Hodges, PW, Hinman RS. Physical impairments and activity limitations in people with femoroacetabular impingement: a systematic review. *Br J Sports Med.* 2015;49(4):230-42.
3. Holla JF, van der Leeden M, Roorda LD, Bierma-Zeinstra SM, Damen J, Dekker J, Steultjens MP. Diagnostic accuracy of range of motion measurements in early symptomatic hip and/or knee osteoarthritis. *Arthritis Care Res (Hoboken).* 2012;64(1):59-65.
4. Reiman MP, Weisbach PC, Glynn PE. The hips influence on low back pain: a distal link to a proximal problem. *J Sport Rehab.* 2009;18(1):24-32.
5. Bencek GJ, Selkowitz DM, Janzen DS, Malecha E, Tiemeyer BR. The influence of pelvic rotation on clinical measurements of hip flexion and extension range of motion across sex and age. *Physical Therapy in Sport.* 2018;30:1-7.
6. Ahlbaeck SO, Lindahl O. Sagittal mobility of the hip-joint. *Acta Orthop Scandinav.* 1964;34:310-22.
7. Bohannon RW, Gajdosik RL, LeVeau BF. Relationship of pelvic and thigh motions during unilateral and bilateral hip flexion. *Phys Ther.* 1985;65(10):1501-04.
8. Kamath BJ, Saraswati V, Bansal A, Pai V. Clinical evaluation of hip joint in sagittal plane using pelvifemoral angle. *J Clin Orthop Trauma.* 2013;4(4):171-3.
9. Boone DC, Azen SP. Normal range of motion of joints in male subjects. *J Bone Joint Surg Am.* 1979;61(5):756-9.
10. Roach KE, Miles TP. Normal hip and knee active range of motion: the relationship to age. *Phys Ther.* 1991;71(9):656-65.
11. Kuo YL, Tully EA, Galea MP. Lumbosacral rhythm during active hip flexion in standing in healthy older adults. *Man Ther.* 2010;15(1):88-92.
12. Poulsen E, Christensen HW, Penny JO, Overgaard S, Vach W, Hartvigsen J. Reproducibility of range of motion and muscle strength measurements in patients with hip osteoarthritis: an inter-rater study. *BMC Musculoskelet Disord.* 2012;6(13):242.
13. Torresman, A. Reprodutibilidade inter e intraavaliador na avaliação funcional do quadril [dissertação]. Porto Alegre: Univ Fed Rio Grande do Sul; 2017.
14. Yazdifar M, Yazdifar M. Evaluating the hip range of motion using the goniometer, the nintendo Wii-mote and video tracking methods. *European Scientific Journal.* 2015;11(21):19-37.
15. Clapis PA, Davis SM, Davis RO. Reliability of inclinometer and goniometric measurements of hip extension flexibility using the modified Thomas test. *Physiother Theory Pract.* 2008;24(2):135-41.
16. Krause DA, Hollman JH, Krych AJ, Kalisvaart MM, BLevy BA. Reliability of hip internal rotation range of motion measurement using a digital inclinometer. *Knee Surg Sports Traumatol Arthrosc.* 2015;23:2562-7.
17. Charltona PC, Mentiplay BF, Puab Y-H, Clark RA. Reliability and concurrent validity of a Smartphone, bubble inclinometer and motion analysis system for measurement of hip joint range of motion. *J Sci Med Sport.* 2015;18(3):262-7.
18. Marques AP, Marcolan JNO, Prado JNN, Burke TN, Ferreira EAG. Inter- and intra-rater reliability of computerized photogrammetry and universal goniometer in the measurement of hip flexion and abduction. *Fisioter Pesqui.* 2017;24(1):22-8.
19. Miki H, Yamanashi W, Nishii T, Sato Y, Yoshikawa H, Sugano N. Anatomic hip range of motion after implantation during total hip arthroplasty as measured by a navigation system. *J Arthroplasty.* 2007;22(7):946-52.
20. Luinge HJ, Veltink PH. Inclinometer measurement of human movement using a 3-D accelerometer with autocalibration. *IEEE.* 2004;12:112-21.
21. Alonge F, Cucco E, D'Ippolito F, Pulizzotto A. The use of accelerometers and gyroscopes to estimate hip and knee angles on gait analysis. *Sensors.* 2014;14:8430-46.
22. American Academy of Orthopaedic Surgeons. Joint motion method of measuring and recording. Chicago; 1965.
23. Gupalov V, Kukaev A, Shevchenko S, Shalymov E, Venediktov V. Physical principles of a piezo accelerometer sensitive to a nearly constant signal. *Sensors (Basel).* 2018;18(10):3258.
24. Svenningsen S, Terjesen T, Aulfem M, Berg, V. Hip motion related to age and sex. *Acta Orthopaedica.* 1989;60(1):97-100.
25. Norkin CC, White DJ. Measurement of joint motion: a guide to goniometry. 5th ed. Philadelphia: F.A. Davis Company.
26. Landis JR, Koch GG. The measurement of observer agreement for categorical data. *Biometrics.* 1977;33(1):159-74.
27. Quantification of pelvic tilt and rotation by width/ height ratio of obturator foramina on anteroposterior radiographs. *Hip Int.* 2016;26(5):462-7.
28. Nishihara S, Sugano N, Nishii T, Ohzono K, Yoshikawa H. Measurements of pelvic flexion angle using three-dimensional computed tomography. *Clin Orthop Relat Res.* 2003;411:140-51.
29. Gilliam J, Brunt D, MacMillan M, Kinard RE, Montgomery WJ. Relationship of the pelvic angle to the sacral angle: measurement of clinical reliability and validity. *J Orthop Sports Phys Ther.* 1994;20(4):193-9.

ASSESSMENT OF THE USE OF TRANEXAMIC ACID AFTER TOTAL KNEE ARTHROPLASTY

AVALIAÇÃO DO USO DO ÁCIDO TRANEXÂMICO DURANTE A ARTROPLASTIA TOTAL DO JOELHO

CHILAN BOU GHOSSON LEITE¹ , LUCAS VERISSIMO RANZONI¹ , PEDRO NOGUEIRA GIGLIO¹ , MARCELO BATISTA BONADIO¹ , LUCAS DA PONTE MELO¹ , MARCO KAWAMURA DEMANGE¹ , RICCARDO GOMES GOBBI¹ 

1. Universidade de São Paulo, Faculdade de Medicina, Department of Orthopedics and Traumatology, São Paulo, SP, Brazil.

ABSTRACT

Objective: To evaluate the profile of blood loss and blood transfusions after the introduction of Tranexamic acid (TXA) in a tertiary university hospital in Brazil. **Methods:** 173 patients were retrospectively divided into two groups: the ones who received TXA and the control group. Hemoglobin levels (Hb), drain output, transfusion rates, and thromboembolic events were measured. **Results:** Among the patients included in this study, 82 cases received TXA. Blood transfusion occurred in 3 cases of the TXA group (3.7%), and in 27 control group cases (29.7%; $p < 0.001$). The average Hb decrease was 2.7 g/dl (± 1.39) and the median drain output was 270 mL in the TXA group. In the control group, the values were 3.41 g/dl (± 1.34 ; $p < 0.001$) and 460 mL ($p < 0.001$), respectively. Thromboembolic events occurred in 2 TXA group cases (2.4%) and in 3 control group cases (3.3%; $p > 0.999$). **Conclusion:** TXA was effective in reducing blood transfusion rates, Hb decrease, and drain output on the 1st postoperative day without increasing thromboembolic events. **Level of evidence III, Retrospective comparative study.**

Keywords: Tranexamic Acid. Blood Transfusion. Knee Replacement Arthroplasty.

RESUMO

Objetivo: Avaliar o perfil de perda sanguínea e hemotransfusões após a introdução da prática do uso de ácido tranexâmico (ATX) em um serviço terciário universitário brasileiro. **Métodos:** 173 pacientes foram separados retrospectivamente em dois grupos: uso do ATX e controle. Foram analisados valores da hemoglobina (Hb), débito do dreno, necessidade transfusional e complicações tromboembólicas. **Resultados:** Dentre os pacientes admitidos no estudo, 82 fizeram uso do ATX. Hemotransfusão ocorreu em 3 casos do grupo ATX (3,7%) e em 27 controles (29,7%, $p < 0,001$). A queda de Hb teve média de 2,7 g/dl ($\pm 1,39$) e o débito do dreno, mediana de 270 ml no grupo ATX. No grupo controle, os valores foram de 3,41 g/dl ($\pm 1,34$; $p < 0,001$) e de 460 ml ($p < 0,001$), respectivamente. Eventos tromboembólicos ocorreram em 2 casos (2,4%) no grupo ATX e em 3 no controle (3,3%, $p > 0,999$). **Conclusão:** o uso do ATX foi efetivo em reduzir hemotransfusões, queda de Hb e débito drenado no 1º dia pós-operatório, sem aumentar eventos tromboembólicos. **Nível de evidência III, Estudo retrospectivo comparativo.**

Descritores: Ácido Tranexâmico. Transfusão de Sangue. Artroplastia do Joelho.

Citation: Leite CBG, Ranzoni LV, Gligio PN, Bonadio MB, Melo LP, Demange MK, Gobbi RG. Assessment of the use of tranexamic acid after total knee arthroplasty. *Acta Ortop Bras.* [online]. 2020;28(2):74-7. Available from URL: <http://www.scielo.br/aob>.

INTRODUCTION

Total knee arthroplasty (TKA) is currently one of the most cost-effective treatments in the management of osteoarthritis in more advanced stages.¹ Patients undergoing TKA are in risk for blood losses over 1500 ml, being submitted to allogenic blood transfusion in 10%-38% of the cases.² Allogenic blood transfusion is not a benign procedure and is associated with complications, such as transmission of infectious diseases, transfusion reactions, fluid overload, and periprosthetic infection.³ In addition, it can lead to

prolonged hospital stay, thromboembolic events, and increased in-hospital mortality.⁴ Different strategies have been used to reduce blood loss after TKA, such as autologous transfusion, cell saver, pneumatic tourniquet, and the use of tranexamic acid (TXA).^{1,5} The fibrinolytic process is a major cause of intraoperative bleeding.³ By acting with the inhibition of hyperfibrinolysis, TXA stabilizes the fibrin clot and reduces blood losses. Mechanistically, it is a competitive inhibitor of plasminogen-activating enzymes, preventing its proteolytic activity to avoid the formation of plasmin and the

All authors declare no potential conflict of interest related to this article.

This study was developed at the Institute of Orthopedics and Traumatology, Hospital das Clínicas, Medical School, Universidade de São Paulo. Correspondence: Chilan Bou Ghossou Leite. Rua Ovídeo Pires de Campos, 333, Cerqueira Cesar, São Paulo, SP, Brazil, 01246000. chilanleite@gmail.com



consequent degradation of fibrin.^{1,6} Several systematic reviews and meta-analyses have demonstrated the TXA role, in cases of TKA, in reducing blood loss and transfusion needs, without increasing the risk of thromboembolic events.⁶⁻⁸

TXA is usually indicated to prevent and treat different causes of bleeding, including large surgical procedures, such as orthopedic, cardiac, and liver transplantation surgeries. In this regard, TXA reduces the need for blood transfusion improving the patient's outcome, therefore its use in polytraumatized patients may decrease mortality by preventing the excessive bleeding.⁹

In recent years, the use of TXA has increased progressively in the TKA worldwide centers. On the other hand, the impact of TXA after TKA is still poorly documented in Brazil. Our service started to use this medication in 2013, introducing the administration of TXA routinely by the end of 2014. Therefore, we could gather a significant amount of experience.

This study aims to evaluate the impact of the TXA routine use, reducing blood loss related to the primary TKA procedure. The study aims to evaluate the hematimetric parameters, the number of transfusions, and the drain output in a retrospective cohort of patients admitted in a tertiary university hospital in Brazil.

MATERIALS AND METHODS

The study was approved by our ethics committee (CAPPesq number 15754619.7.0000.0068). All patients signed an informed consent form. A retrospective cohort study was carried out with patients undergoing TKA between 2013 and 2017 admitted in our service.

Patients were not included in the study if they had:

- any hematological diseases, renal insufficiency, hepatic insufficiency, previous cardiovascular and/or thromboembolic events;
- preoperative use of anticoagulant or other medications that alter coagulation;
- alteration in coagulation exams prior to the surgical procedure;
- intraoperative fracture that required the use of intramedullary nails and revision components.

Based on that, 220 patients were selected. Of those, 47 were excluded due to the lack of medical records information. Totally, 173 cases were included in the study.

The cases were separated based on the TXA use. The clinical protocol allowed the administration of the highest TXA dose between 1 g or 10 mg/kg during anesthetic induction, with or without a dose replication just before the tourniquet deflation.

Demographic data were collected. In addition, information regarding the administered TXA dose, the levels of preoperative hemoglobin (Hb), the hemoglobin on the 3rd postoperative day, and the drain output on the 1st postoperative day were evaluated. The need for transfusion was indicated intraoperatively by the anesthesiologist according to subjective criteria, or by the clinician postoperatively, when Hb < 7 g/dl or Hb > 7 g/dl with clinical repercussions. Thromboembolic complications or hematoma formation requiring joint aspiration, and the total hospital/ICU length of stay were analyzed. As an exploratory analysis, this study also compared the patients' subgroup that received or not blood transfusion, regarding the need for hospitalization in the ICU, and the total hospital and ICU length of stay.

Statistical analysis

Numerical variables were described as mean and standard deviation when normal distribution in groups, or as median and interquartile range (IR) when non-normal distribution, according to Shapiro-Wilk test and Histogram analysis. Categorical variables were described by the absolute number and percentage within the group. In the univariate analyses, for numerical variables between groups, the Student's t-test or the Mann-Whitney U test was used, according to the variable's

normality. In the categorical variables the Fisher's test in the respective contingency tables was used. To evaluate the determinants of the need for transfusion with control of possible confounding variables, multivariate binomial logistic regression was performed, including the following variables: sex, age, use of tranexamic acid, and drain use. Statistical significance was considered when $p < 0.05$.

RESULTS

Demographic characteristics

From 2013 to 2017, a total of 220 patients undergoing primary TKA surgery in our service had their data adequately recorded. Of this total, 173 patients were included based on the eligibility criteria of this study. Demographic characteristics showed no significant difference between groups (Table 1). Forty-seven (57.3%) patients received two doses of TXA.

Table 1. Patient demographics. Age is shown in years \pm standard deviation; sex and diagnosis are described as n (%).

	TXA Group (n = 82)	Control group (n = 91)	TOTAL (n = 173)	p*
Age	66.5 11.4	65.4 10.4	65.9 10.9	0.525
Sex				0.318
Male	18 (22)	26 (28.6)	44 (25.4)	
Female	64 (78)	65 (71.4)	129 (74.6)	
Diagnosis				0.864
Primary Osteoarthritis	64 (78)	72 (79.1)	136 (78.6)	
Others	18 (22)	19 (20.9)	37 (21.4)	

*Fisher's Test

Blood loss

Table 2 shows the parameters associated to blood loss, such as Hb levels, drain output, and need for transfusion.

Table 2. Values related to blood loss. The values are shown as mean \pm standard deviation or as median/IR. In the case of blood transfusion, the values are expressed in n (%).

	TXA group	Control group	p
Hb preoperative	13.57 1.32	13.54 1.26	0.867 ¹
Hb postoperative (PO)	10.87 1.66	10.13 1.42	0.002 ¹
Hb decrease	2.70 1.39	3.41 1.34	< 0.001 ¹
1st PO drain output	270/290	460/575	< 0.001 ²
Blood transfusion	3 (10)	27 (90)	< 0.001 ¹

1: Student's t-test; 2: Mann-Whitney U test.

The mean preoperative Hb was 13.5 g/dl (\pm 1.32) in the TXA group and 13.5 g/dl (\pm 1.26) in the control group ($p = 0.867$). On the 3rd postoperative day, the Hb levels were significantly higher in the TXA group in comparison with the control group (10.87 g/dl \pm 1.66 vs 10.13 g/dl \pm 1.42, respectively). TXA-treated patients had a smaller Hb decrease than the control group (2.7 g/dl \pm 1.39 vs 3.41 g/dl \pm 1.34; $p < 0.001$). Moreover, the median drain output on the 1st postoperative day was significantly reduced in the TXA group when compared with the control group.

Hemotransfusion was performed in 30 patients. Most transfusion cases were from the control group (90%), while a small proportion of the TXA-treated patients (10%) needed transfusion.

Length of stays and need for ICU

The mean length of stay in hospital was 5.17 days for the TXA group and 7.70 for the control one. Regarding the need for ICU,

62 (35.8%) patients required intensive postoperative support, 28 (34.1%) in the TXA group and 34 (37.4%) in the control group. The mean ICU length stay was 0.41 (\pm 0.68) days for the TXA group and 1.86 (\pm 7.66) for the control group.

As an exploratory analysis, this study correlated blood transfusion with the total hospital and ICU length of stay. For patients undergoing transfusion, the mean total hospitalization stay was 13.83 days, compared with 4.97 days of non-transfused patients ($p = 0.002$). Similarly, the mean ICU stay was 5.17 days for those who received blood and 0.34 days for those who did not receive blood transfusion ($p < 0.001$).

Moreover, the relationship between transfusion events and the need for ICU admission also showed statistical significance. Of the 30 patients receiving transfusion, 19 (63.3%) were referred to the ICU, while 11 (36.7%) did not require intensive care ($p = 0.001$).

Complications

Thromboembolic events and hematoma formation were evaluated as complications of TKA and accounted for 8.67% of the participants. Thromboembolic events occurred in 5 cases and hematoma formation that required joint aspiration occurred in 10 cases. No statistically significant difference was found between the groups (Table 3).

Table 3. Complications. The values are shown in n (%).

	TXA group	Control group	TOTAL	<i>p</i> *
Thromboembolic events	2 (2.4)	3 (3.3)	5 (2.9)	> 0.999
Hematoma	4 (4.9)	6 (6.6)	10 (5.8)	0.750

*Fisher's Test.

The multivariate evaluation by logistic regression was performed and included the following variables: sex, age, use of tranexamic acid, and drain output. Among the variables, only the use of TXA was correlated to the need for blood transfusion (odds ratio [OR], 0.097 {95% confidence interval [CI]}; 0.027-0.344, $p = 0.001$). This suggests the TXA afforded a protection from the need for transfusion of approximately 10 times.

DISCUSSION

In this study, we showed the effective use of TXA in decreasing the perioperative transfusion requirement. In addition, it reduced the hemoglobin decrease and the drain output on the 1st postoperative day. These results are similar to those found in the literature. Many studies show a favorable correlation between the use of TXA and the decrease in intra and postoperative bleeding during the TKA surgery.^{10,11} Its efficacy and safety has been well studied recently.¹² A Cochrane review conducted by Henry et al. (2011) showed that TXA efficiently decreased blood loss during and after orthopedic procedures, reducing it in approximately 446.19 ml (95%CI 554.61-337.78 ml).¹³ In this regard, Yang et al.⁷, in a meta-analysis study, showed a significantly lower value in blood transfusion rates in patients who used TXA compared with the placebo group (OR 0.16, 95%CI 0.10-0.25; $p < 0.001$) (7). Similarly, the systematic review and meta-analysis conducted by Alshryda et al. (2011) show the use of TXA significantly reduced perioperative blood loss in over 591 ml (95%CI 536-647; $p < 0.001$) and the need for blood transfusion (RR 2.56, 95% CI 2.1-3.1; $p < 0.001$), without increasing the risk of adverse events, regardless of the via of administration (oral, topical, or intravenous).¹⁴

Besides the growing interest in TXA studies, there is no absolute conclusion of the best administration *via* (intravenous, intra-articular, topical, or oral)¹⁵, dose, and the number of required

applications for the best results.⁸ The review performed by Melvin et al.¹⁶ indicates that the effective dose has ranged from 1 g to 10-20 mg/kg of TXA, applied intravenously or topical, without significant different outcome. Although it is proposed that the number of doses may influence the reduction of blood loss¹⁷, there is no consensus about the best administration regimen. In this study, the TXA was administered intravenously using the highest dose between 1 g or 10 mg/kg during anesthetic induction. Some of the cases had the treatment replicated immediately before the pneumatic tourniquet disinflation. Given the retrospective analysis of this study, there was no dose standardization, which is a limitation of the study.

Despite the good obtained results, the TXA also presents theoretical risks, such as deep vein thrombosis (DVT) and pulmonary thromboembolism (PE). Based on its mechanism of action, TXA might activate coagulation cascade and increase the tendency of thrombus formation. However, Alshryda et al.¹⁴ showed no increase in the risk of these complications after the use of the TXA. Moreover, Sabbag et al.¹⁸ conducted a retrospective study of patients with thromboembolic events history prior to TKA. They concluded that the recurrence of these events is uncommon after surgery, with no significant increase in incidence related to the use of TXA compared with the placebo group (2.3% versus 1.9% respectively; $p = 0.599$).¹⁸

The incidence of DVT and pulmonary embolism after TKA surgery without an adequate prophylaxis was estimated to be 41%-85% and 1.5%-10%, respectively. Adequate prophylaxis reduces this incidence to approximately 1% during hospitalization.¹⁹ In this study, prophylaxis was made with Enoxaparin 40 mg/day for 14 days. The study found 5 thromboembolic events, 2 (2.4%) of those in TXA group and 3 (3.3%) in the control group, without significant association regarding the use of TXA ($p > 0.999$). The perioperative blood transfusion itself could also increase the risk of DVT after arthroplasty surgeries, by increasing blood viscosity, causing erythrocytes and platelets aggregation with subsequent thrombus formation.²⁰ Thus, decreasing the number of blood transfusions would improve the occurrence of these events.

As stated in this study with exploratory analysis, patients undergoing blood transfusion have a greater need for postoperative intensive care. Likewise, there was a positive correlation between the blood transfusion and the hospital and ICU length of stay. The use of TXA, by reducing the need for blood transfusion, would also be beneficial in decreasing the need for postoperative ICU, and the hospital and ICU length of stay. Randomized controlled trials are required to improve the understanding of this correlation.

The study had several limitations. Because it is a retrospective study, the patients may have different demographic characteristics. Moreover, as mentioned before, there was no standardization in the number of TXA applications (one or two doses). It was not possible to define the dose influence that in fact decreases perioperative bleeding. Additional studies would be useful to clarify these variables. Another limitation is the lack of real blood loss measurement, which was made by indirect methods, such as drain output and Hb decrease. Of note, there is a small difference in postoperative Hb between the groups, despite the statistically significant result (averages of 2.7 g/dl (\pm 1.39) in the TXA group and 3.41 g/dl (\pm 1.34) in the control group. This value refers to the 3rd postoperative day and, therefore, after blood transfusions. Since the control group was subjected to a more expressive number of transfusions, the Hb could be underestimated in these cases.

In this study, the primary outcome was the reduction of blood transfusions required after the TKA. The study considered this as one of the most faithful clinical expressions of blood loss. It is important

to emphasize that the indication for postoperative transfusion was made by a clinical team, which was unaware of the TXA use. Despite the limitations, this study is one of the few in the national literature to compare the use of TXA with a control group. Furthermore, the study shows the successful use of TXA in reducing the transfusion requirement, the postoperative Hb decrease, and the drain output in a pragmatic situation of an uncontrolled study.

CONCLUSION

In conclusion, the use of TXA had a positive role after TKA in our service. It significantly reduced the blood transfusion rates, being a potent tool in the therapeutic arsenal, aiming to improve the clinical and surgical conditions related to the TKA procedure and the perioperative period.

AUTHORS' CONTRIBUTIONS: Each author contributed individually and significantly to the development of this article. MKD and MBB: study design; LVR and LPM: data collection; CBGL: writing of the article and data analysis; PNG: statistical and data analyses, and article review; RGG: intellectual concept, data analysis, and article review.

REFERENCES

1. Levine BR, Haugom B, Strong B, Hellman M, Frank RM. Blood management strategies for total knee arthroplasty. *J Am Acad Orthop Surg.* 2014;22(6):361-71.
2. Wong J, Abrishami A, El Beheiry H, Mahomed NN, Roderick Davey J, Gandhi R, et al. Topical application of tranexamic acid reduces postoperative blood loss in total knee arthroplasty: a randomized, controlled trial. *J Bone Joint Surg Am.* 2010;92(15):2503-13.
3. Tang Y, Wen Y, Li W, Li H, Yang Y, Liu Y. The efficacy and safety of multiple doses of oral tranexamic acid on blood loss, inflammatory and fibrinolysis response following total knee arthroplasty: a randomized controlled trial. *Int J Surg.* 2019;65:45-51.
4. Huang Z, Huang C, Xie J, Ma J, Cao G, Huang Q, et al. Analysis of a large dataset to identify predictors of blood transfusion in primary total hip and knee arthroplasty. *Transfusion.* 2018;58(8):1855-62.
5. Su EP, Su S. Strategies for reducing peri-operative blood loss in total knee arthroplasty. *Bone Joint J.* 2016;98-B(1):98-100.
6. Riaz O, Aqil A, Asmar S, Vanker R, Hahnel J, Brew C, et al. Epsilon-aminocaproic acid versus tranexamic acid in total knee arthroplasty: a meta-analysis study. *J Orthop Traumatol.* 2019;20(1):28.
7. Yang ZG, Chen WP, Wu LD. Effectiveness and safety of tranexamic acid in reducing blood loss in total knee arthroplasty: a meta-analysis. *J Bone Joint Surg Am.* 2012;94(13):1153-9.
8. Kim TK, Chang CB, Koh IJ. Practical issues for the use of tranexamic acid in total knee arthroplasty: a systematic review. *Knee Surg Sports Traumatol Arthrosc.* 2014;22(8):1849-58.
9. Pabinger I, Fries D, Schöchl H, Streif W, Toller W. Tranexamic acid for treatment and prophylaxis of bleeding and hyperfibrinolysis. *Wien Klin Wochenschr.* 2017;129(9-10):303-16.
10. Tanaka N, Sakahashi H, Sato E, Hirose K, Ishima T, Ishii S. Timing of the administration of tranexamic acid for maximum reduction in blood loss in arthroplasty of the knee. *J Bone Joint Surg Br.* 2001;83(5):702-5.
11. Sassoon A, Nam D, Jackups R, Johnson SR, Nunley RM, Barrack RL. Tranexamic acid: optimal blood loss management in surface replacement arthroplasty. *Bone Joint J.* 2016;98-B(2):173-8.
12. Whiting DR, Gillette BP, Duncan C, Smith H, Pagnano MW, Sierra RJ. Preliminary results suggest tranexamic acid is safe and effective in arthroplasty patients with severe comorbidities. *Clin Orthop Relat Res.* 2014;472(1):66-72.
13. Henry DA, Carless PA, Moxey AJ, O'Connell D, Stokes BJ, Fergusson DA, Ker K. Anti-fibrinolytic use for minimising perioperative allogeneic blood transfusion. *Cochrane Database Syst Rev.* 2011;(1):CD001886.
14. Alshryda S, Sarda P, Sukeik M, Nargol A, Blenkinsopp J, Mason JM. Tranexamic acid in total knee replacement: a systematic review and meta-analysis. *J Bone Joint Surg Br.* 2011;93(12):1577-85.
15. Xu S, Chen JY, Zheng Q, Lo NN, Chia SL, Tay KJD, et al. The safest and most efficacious route of tranexamic acid administration in total joint arthroplasty: a systematic review and network meta-analysis. *Thromb Res.* 2019;176:61-6.
16. Melvin JS, Stryker LS, Sierra RJ. Tranexamic acid in hip and knee arthroplasty. *J Am Acad Orthop Surg.* 2015;23(12):732-40.
17. Drosos GI, Ververidis A, Valkanis C, Tripsianis G, Stavroulakis E, Vogiatzaki T, Kazakos K. A randomized comparative study of topical versus intravenous tranexamic acid administration in enhanced recovery after surgery (ERAS) total knee replacement. *J Orthop.* 2016;13(3):127-31.
18. Sabbag OD, Abdel MP, Amundson AW, Larson DR, Pagnano MW. Tranexamic acid was safe in arthroplasty patients with a history of venous thromboembolism: a matched outcome study. *J Arthroplasty.* 2017;32(9S):S246-50.
19. Januel JM, Chen G, Ruffieux C, Quan H, Douketis JD, Crowther MA, et al. Symptomatic in-hospital deep vein thrombosis and pulmonary embolism following hip and knee arthroplasty among patients receiving recommended prophylaxis: a systematic review. *JAMA.* 2012;307(3):294-303.
20. Jiang T, Song K, Yao Y, Pan P, Jiang Q. Perioperative allogenic blood transfusion increases the incidence of postoperative deep vein thrombosis in total knee and hip arthroplasty. *J Orthop Surg Res.* 2019;14(1):235.

FACTORS AFFECTING THE FUNCTIONAL OUTCOME OF OXFORD PHASE 3 UNICOMPARTMENTAL KNEE ARTHROPLASTY

FATORES QUE AFETAM O RESULTADO FUNCIONAL DA ARTROPLASTIA UNICOMPARTIMENTAL DO JOELHO OXFORD PHASE 3

AYŞE ESİN POLAT¹ , BARIŞ POLAT² , TAHSİN GÜRPINAR³ , BARIŞ PEKER⁴ , TOLGA TÜZÜNER⁵ 

1. Dr. Akçiçek State Hospital, Orthopaedics and Traumatology Department, Kyrenia, Turkish Republic of Northern Cyprus.

2. University of Kyrenia, Orthopaedics and Traumatology Department, Kyrenia, Turkish Republic of Northern Cyprus.

3. Istanbul Training and Research Hospital, Orthopaedics and Traumatology Department, Istanbul, Turkey.

4. Dr. Burhan Nalbantoğlu State Hospital, Orthopaedics and Traumatology Department, Nicosia, Turkish Republic of Northern Cyprus.

5. Acıbadem Bakırköy Hospital, Orthopaedics and Traumatology Department, Istanbul, Turkey.

ABSTRACT

Objective: To determine the factors that affect the functional outcome of Oxford Phase 3 unicompartmental knee arthroplasty (UKA). **Methods:** We assessed a total of 52 UKA knees of 49 patients with a minimum follow-up of 2 years (24-72 months). We recorded the results for Range of motion (ROM) and body mass index (BMI) and the presence of patello-femoral arthrosis (PFA). In the radiological evaluation, we measured the posterior tibial slope (PTS), the tibial plateau angle (TPA) and the femorotibial angle, in addition to an assessment using the Oxford radiological criteria. Patients were grouped by age, follow-up time, BMI, radiological criteria, PFA presence, occurrence of complications and revision surgery. The clinical and functional results of these groups were compared statistically. **Results:** A total of 40 women and 9 men participated in the study, with an average age of 60 years, and a mean BMI of 34.6. No significant differences were found among the age and PFA groups. Postop VAS scores were high and knee evaluation scores were significantly lower in the morbidly obese group and in the groups with postop TPA <85° and >90°. The revision ratio was 11.5%. **Conclusion:** Postop TPA, PTS and morbid obesity are the most significant factors that can lead to revision surgery. **Level of Evidence IV, Case series.**

Keywords: Osteoarthritis. Arthroplasty. Replacement. Knee. Pain.

RESUMO

Objetivo: Determinar os fatores que afetam o resultado funcional da artroplastia unicompartmental do joelho Oxford Phase 3 (AUJ). **Métodos:** Foram incluídos 52 joelhos AUJ de 49 pacientes com um período mínimo de 2 anos (24-72 meses) de acompanhamento. Foram registrados: amplitude de movimento (ADM), índice de massa corporal (IMC) e presença de artrose femoropatelar (AFP). Na avaliação radiológica, medimos o declive tibial posterior (DTP), o ângulo do planalto tibial (APT) e o ângulo femorotibial, além de usarmos os critérios radiológicos de Oxford. Os pacientes foram agrupados de por idade, tempo de acompanhamento, IMC, critérios radiológicos, presença de AFP e ocorrência de complicações e cirurgias de revisão. Os resultados clínicos e funcionais desses grupos foram comparados estatisticamente. **Resultados:** Participaram do estudo 40 pacientes do gênero feminino e 9 do gênero masculino, com idade média de 60 anos, IMC de 34,6. Não foram encontradas diferenças significativas entre os grupos formados por idade e presença de AFP. As marcações da EVA pós-operatória foram altas e as marcações do joelho foram significativamente baixas no grupo com obesidade mórbida e nos grupos com APT pós-operatória <85° e >90°. A taxa de revisão foi de 11,5%. **Conclusão:** APT e DTP pós-operatório e obesidade mórbida são os fatores mais significativos que podem levar à cirurgia de revisão. **Nível de Evidência IV, Série de casos.**

Descritores: Osteoartrite. Artroplastia do Joelho. Dor.

Citation: Polat AE, Polat B, Gürpınar T, Peker B, Tüzüner T. Factors affecting the functional outcome of Oxford phase 3 unicompartmental knee arthroplasty. *Acta Ortop Bras.* [online]. 2020;28(2):78-83. Available from URL: <http://www.scielo.br/aob>.

All authors declare no potential conflict of interest related to this article.

The study was conducted at Istanbul Training and Research Hospital, Orthopaedics and Traumatology Department.
Correspondence: Barış Polat, Şehit Yahya Bakır Street, 10, Kyrenia, Cyprus. drbpolat@hotmail.com



INTRODUCTION

Osteoarthritis is the most common joint disease in the world and the most frequent cause of chronic musculoskeletal pain.¹ In 80-90% of the cases, osteoarthritis begins in the medial compartment and tends to remain unicompartmental.² There are different types of surgical treatment for single compartment osteoarthritis, including Total Knee Arthroplasty (TKA), High Tibial Osteotomy or Unicompartmental Knee Arthroplasty (UKA), when conservative treatments are not responsive. Oxford Phase 3 UKA, was introduced in 1998 by Murray and Goodfellow et al.³ Many advantages of the UKA are mentioned in the literature, including: minimally invasive incision, preservation of the anterior and posterior cruciate ligaments, fewer bone cuts, less postoperative blood loss and pain, better functional outcomes, reduced hospitalization time, lower costs and faster and earlier rehabilitation.^{4,5} Its disadvantages include surgical technical difficulties and experience requirements.⁴⁻⁷ Additionally, higher revision rates have been reported for UKA compared to total knee arthroplasty (TKA).⁸ Improper patient selection and implant malpositioning may be responsible for this high rate.^{5,7,9}

With the development of implants, component materials, surgical fixation techniques, and the definition of correct indications and correct patient selection criteria, positive results have been recorded for UKA in the last 20 years.^{6,10,11}

All surgeons must analyse the pitfalls and underlying clinical and radiological reasons for early failure of UKA before performing this procedure. However, as the surgeons' experience increases, their surgical technique improves, ensuring a more accurate implant positioning. We aimed to evaluate radiological and clinical results and determine the factors that affect the functional outcome of Oxford Phase 3 unicompartmental knee arthroplasty cases. This study also intends to be a helpful tool for surgeons, identifying the causes of early failure of UKA.

MATERIAL AND METHODS

Participants

In this retrospective study, we analysed 52 knees of 49 patients who underwent Oxford Phase 3 unicompartmental knee arthroplasties (Oxford Partial Knee, Biomet Orthopaedics, Bridgend, UK) for anteromedial osteoarthritis. These surgeries were performed by the last author (TT) or under his control, in the Orthopaedics and Traumatology Clinic of the Istanbul Training and Research Hospital, between 2011 and 2016. The inclusion criteria were: presenting non-inflammatory arthritis with an intact anterior cruciate ligament, passively correctable angular deformity under 10° varus and 5° valgus, flexion deformity under 15° and no lateral compartment involvement. Patients with a minimum follow-up of 2 years were included. This study was approved by the Research Ethics Committee (ID:47 date:07/06/2016). All patients who took part in this study signed forms of informed consent, agreeing to its publishing.

Clinical and radiological evaluation

As part of the preoperative radiological evaluation, we assessed weight-bearing anteroposterior and flexed lateral knee X-rays, patella tangential X-rays, varus-valgus stress X-rays and orthoroentgenograms. Preoperatively, all 52 knees underwent MRI examinations. The groups divided according to the presence of patellofemoral arthrosis (PFA) were based on its grading shown in the Magnetic resonance imaging (MRI). Postoperatively, we performed orthoroentgenograms, weight-bearing anteroposterior and flexed lateral knee X-ray imaging.

For the evaluation of the patients, pre and postoperatively, we used the Knee Society Score (KSS) and functional Knee Society Score (fKSS), the Oxford Knee Score (OKS) and the visual analogue scale (VAS). The range of motion (ROM) was also recorded for each patient pre and postoperatively. Additionally, the body mass index (BMI) and the presence of patellofemoral arthrosis (PFA) were documented. In the radiological evaluation, we assessed the posterior tibial slope (PTS), the tibial plateau angle (TPA) and the femorotibial angle (FTA), besides using the Oxford radiological criteria (Table 1) (Figure 1). Preop and postop FTA are measured by the angle between the two lines drawn from the centers of the femur and tibia, which start 10 cm above and below the joint line. Preop and postop PTS are defined by the angle between the tibial anatomical axis and the line drawn tangentially to the medial tibial plateau on the lateral radiographs. The preop TPA is the angle between the tibial plateau and the tibial anatomic axis, whereas the postop TPA is measured between the tibia anatomic axis and the tangential line of the medial plateau implant cuts. Two authors (AEP and TG) assessed all images and measured all angles independently. The images were blinded, and their order was randomized. When there was a disagreement between the examiners, re-evaluations were made until a consensus was reached. Patients were grouped according to their ages, follow-up time, BMI, varus-valgus and flexion-extension positions of the femoral component, FTA, PTS, TPA, PFA presence in MRI, occurrence of complications and revision surgeries. The clinical and postoperative ROM results of these groups were statistically compared.

Table 1. Oxford radiological criteria.

	Description	Criterion
Femoral component		
A/A	Varus/valgus angle	< 10° varus to < 10° valgus
B/B	Flexion/extension angle	< 5° flexion to < 5° extension
C/C	Medial/lateral placement	Central
D	Posterior fit	Flush/ < 2 mm overhang
Tibial component		
E/E	Varus/valgus angle	< 10° varus to < 5° valgus
F/F	Posteroinferior tilt	7° ± 5°
G	Medial fit	Flush or < 2 mm overhang
H	Posterior fit	Flush or < 2 mm overhang
J	Anterior fit	Flush or < 3 mm overhang
K	Lateral fit	Flush, no gap

Source: Oxford Phase 3 unicompartmental knee prosthesis user's manual.

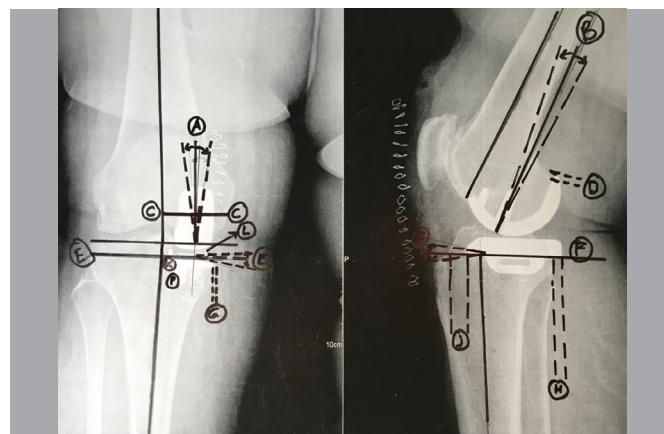

Figure 1. Postoperative correct positioning of unicompartmental knee arthroplasty according to Oxford radiological criteria.

Statistical analysis

For the statistical analysis, we used the SPSS 15.0 software for Windows. The ratio of categorical variables in the groups was tested by Chi-square analysis. The Monte Carlo simulation was applied when the conditions were not met. Because the numerical variables presented no normal distribution, two independent group comparisons were made using the Mann-Whitney U test and the Kruskal Wallis test in all groups. Subgroup analysis was done using Mann-Whitney U test and interpreted by Bonferroni correction. The relationships between numerical variables were examined by Spearman correlation analysis, since the parametric test conditions were not provided. The Cox Regression Analysis Forward Method was used in the model, based on the factors that could affect the revision rates. Statistical significance level alpha was accepted as $p < 0.05$.

RESULTS

In total, 40 patients (81.6%) were women and 9 (18.4%) were men. Their mean age was 60 years (in a range of 49-80), and their mean BMI was 34.6 (in a range of 22-56.9). Two (3.8%) of the patients had normal weight (BMI below 25 kg/m²), 11 (21.2%) were overweight (BMI, 25-29.9 kg/m²), 31 (59.6%) were obese (BMI, 30-34.9 kg/m²) and 8 (15.4%) were morbidly obese (BMI \geq 35 kg/m²). The left knees of 21 patients, the right knees of 28 patients and both knees of 3 patients underwent UKA. The mean follow-up period of the patients was 48 months (ranging between 24 and 72 months). The average OKS, KSS and fKSS scores improved significantly, from 12.7, 43.3 and 34.8 in preoperative measurements to 37.8, 85.7 and 82 in postoperative measurements, respectively, and the mean VAS scores decreased from 9 to 2.6. Additionally, ROM improved from 111° to 123° (Table 2). According to the Oxford radiological criteria, component replacement error was found in 19 (36.5%) patients. The most common error was a defective central placement of the femoral component. However, the most frequent problems in the revised knees were errors in the lateral placement of the tibial component – more than 10° varus or valgus of the tibial component, or more than 10° varus or valgus of the femoral component – and posterior tibial slope defects. All three patients with PTS misplacement underwent revision surgery (Table 3).

Table 2. Pre and postoperative scores.

		Preoperative	Postoperative	p
ROM		111.2 ± 12.6 (90-130)	123.6 ± 14.6 (75-135)	< 0.001
KSS		43.3 ± 9.7 (17-69)	85.7 ± 19.9 (31-100)	< 0.001
n (%)	Excellent	—	40 (76.9)	
	Good	—	5 (9.6)	
	Fair	2 (3.8)	2 (3.8)	
	Poor	50 (96.2)	5 (9.6)	
fKSS		34.8 ± 19.0 (0-90)	82.0 ± 24.4 (0-100)	< 0.001
n (%)	Excellent	1 (1.9)	38 (73.1)	
	Good	1 (1.9)	7 (13.5)	
	Fair	2 (3.8)	2 (3.8)	
	Poor	48 (92.3)	5 (9.6)	
OKS		12.7 ± 7.8 (0-32)	37.8 ± 10.4 (7-48)	< 0.001
n (%)	Severe	43 (82.7)	6 (11.5)	
	Moderate	6 (11.5)	2 (3.8)	
	Mild	3 (5.8)	6 (11.5)	
	Normal	—	38 (73.1)	
VAS		9.0 ± 1.1 (6-10)	2.6 ± 2.9 (0-10)	< 0.001

OKS: Oxford Knee Score; KSS: Knee Society Score; fKSS: functional Knee Society Score; ROM: range of motion; VAS: visual analogue scale.
Values are shown as mean ± SD (range) unless otherwise indicated.

Table 3. Defects and revision percentages according to Oxford radiological criteria.

Criterion	Defects	Revisions
A. Femoral component > 10° varus-valgus positioning defect	3 (5.7)	2 (66.6)
B. Femoral component > 5° of flexion-extension positioning defect	4 (7.69)	—
C. Femoral component central positioning defect at coronal plane	12 (23)	2 (16.6)
D. Femoral component posterior fit defect	—	—
E. Tibial component > 10° varus-valgus positioning defect	2 (3.8)	2 (100)
F. Posterior tibial tilt defect	3 (5.7)	3 (100)
G. Tibial component more than 2 mm medial flush	1 (1.9)	1 (100)
H. Tibial component posterior fit defect	—	—
J. Tibial component anterior fit defect	1 (1.9)	—
K. Tibial component lateral fit defect	4 (7.69)	3 (75)
L. Insert positioning	—	—

Values are shown as n (%).

Patients were grouped according to the following postoperative measured angles: PTS (87° – 79° is normal), FTA (over 175° is varus, 170° – 175° is normal, under 170° is valgus) and TPA (over 90° is valgus, 90° normal, 89° – 85° is minor varus, under 85° is varus). KSS, fKSS, OKS, VAS and ROM were compared postoperatively in these groups (Tables 4 and 5).

Table 4. Preoperative and postoperative mean values.

		Preoperative	Postoperative	p
PTS		82.9 ± 1.9 (78-87)	84.0 ± 4.0 (76-102)	0.074
n (%)	> 87	—	5 (9.6)	
	87-79	51 (98.1)	41 (78.8)	
	< 79	1 (1.9)	6 (11.5)	
FTA		179.4 ± 3.0 (174-190)	174.9 ± 4.6 (162-185)	< 0.001
n (%)	> 175	47 (90.4)	20 (38.5)	
	175-170	5 (9.6)	28 (53.8)	
	< 170	—	4 (7.7)	
TPA		84.8 ± 2.7 (80-90)	88.7 ± 3.7 (72-98)	< 0.001
n (%)	> 90	—	2 (3.8)	
	90 (normal)	4 (7.7)	34 (65.4)	
	85-89	25 (48.1)	11 (21.2)	
	< 85	23 (44.2)	5 (9.6)	

PTS: posterior tibial slope; FTA: femorotibial angle; TPA: tibial plateau angle.
Values are shown as mean ± SD (range) unless otherwise indicated.

Table 5. Comparison of postoperative clinical scores in the postoperative tibial plateau angle groups

	Tibial plateau angle								
	> 90*		90 (normal)		85-89		< 85		P
	Ort.	SD	Ort.	SD	Ort.	SD	Ort.	SD	
ROM postop	112.5	31.8	124.9	14.1	127.7	8.2	110	17.7	0.933
KSS postop	54.0	32.5	88.5	17.0	94.7	6.6	59.4	25.2	0.010
fKSS postop	45.0	63.6	84.4	19.3	92.3	11.7	58.0	37.7	0.048
OKS postop	21.0	12.7	38.8	9.6	42.9	3.3	26.4	12.4	0.014
VAS postop	6.00	4.24	2.24	2.74	1.45	1.92	6.00	2.92	0.020

ROM: range of motion; KSS: Knee Society Score; fKSS: functional score; OKS: Oxford Knee Score; VAS: visual analogue scale.

The patients, whose mean age was 60 years, were divided into three age groups: those younger than 55 years, those between

55 and 65 years, and those older than 65 years. There were no statistically significant differences among these groups. Furthermore, there were no statistically significant differences among the patients grouped according to the presence of PFA, identified by MRI. In the morbidly obese group, the postop clinical scores were significantly lower and the VAS scores, significantly higher, while clinical scores were excellent in the other BMI groups.

Complications developed in five patients (9.6%). Three of the complications were intra-operative eminence fractures and two of them were insert dislocations. The eminence fractures occurred in the first UKA surgery experiences, while the surgeon was making a horizontal tibial cut, and were fixed intra-operatively with two headless cannulated screws (Figure 2). In the subsequent surgeries, a sagittal saw was used to avoid this complication. Two of these patients underwent revision surgeries, 7 months and 45 months after the UKA operation. The eminence fracture healed completely with the revision. Both these patients also had implant misplacement. The other patient with an eminence fracture did not have any implant placement defects and their postoperative functional outcomes were good. Two patients were referred to the authors' clinic because of ROM limitations, and insert dislocations were diagnosed at 3 and 10 months after the operation. Both patients had a history of knee distortion. Radiologic evaluations of the patients with insert dislocation did not reveal any misplacement at implantation, except for the central placement of the femoral component (placed 4 mm or 3 mm laterally). Furthermore, two of the five patients who developed complications were morbidly obese and three of them were obese.



Figure 2. Eminence fracture fixed intra-operatively with two headless cannulated screws.

Six (11.5%) of the patients required revision (Table 6). The UKA revision rate in the authors' clinic was 11.5%, while the TKA revision rate for the same period was 8%; UKAs performed between 2011-2016 accounted for 4.6% of the knee replacement surgeries conducted during that period.

Using the Cox Regression Analysis, Forward Method, we assessed the age, sex, BMI, presence of PFA, postop TPA, postop FTA, postop PTS, varus and valgus alignment of femoral component and follow-up times, composing a model of the factors that could lead to the need of revision. In this analysis, the postop tibial plateau angle (Figure 3), the postop posterior tibial slope (Figure 4) and morbid obesity were determined as the most significant factors that could lead to revision.

Table 6. Summary of findings on revision patients.

	PTS\F	FTA	TPA\E	Fem component VARUS\VALGUS\	C	G	J	K	BMI	Complication	Revision Cause	Revision time	Age	Revision implant
1	102	183	78 VAR	N	N	N	4 mm Posterior	1 mm	38.7	None	T. loosening + collapse	52nd m.	53	Constrain
2	90	N	84 VAR	N	N	N	N	N	33	Eminence fracture	T.+F. loosening	45th m.	65	Primer
3	N	183	N	12 VAR	2 mm Med	N	N	1 mm	41.6	Eminence fracture	T. loosening + collapse	7th m.	58	Primer
4	N	N	N	N	N	N	N	N	47	None	T.+F. loosening	7th m.	51	Primer
5	N	183	98 VAL	N	3 mm Med	3 mm Med	N	2 mm	50	None	T. loosening + collapse	12nd m.	53	Constrain
6	76	185	72 VAR	12 VAR	3 mm Med	N	N	N	49	None	T.+F. loosening	12nd m.	56	Primer

BMI: body mass index; C: femoral component central positioning; FTA: femorotibial angle; G: tibial component more than 2 mm medial flush; J: tibial component anterior fit defect; K: tibial component lateral fit defect; m: month; N: normal; PTS\F: posterior tibial slope or F:posterior tibial tilt; T: tibial; F: femoral; TPA\E: tibial plateau angle or E: tibial component varus-valgus; VAR: varus. VAL: valgus; Med: medial; mm: millimeter.

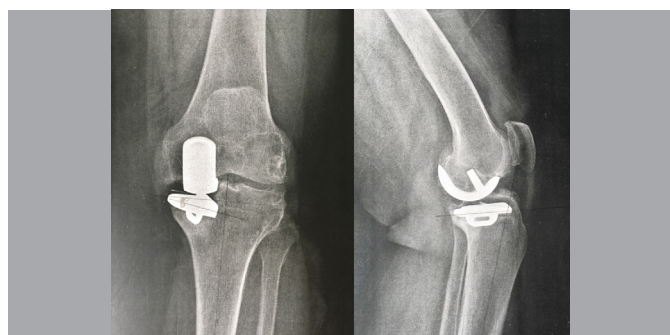

Figure 3. 4th year postoperatively, anteroposterior/lateral X-ray view of unicompartmental knee arthroplasty with tibial plateau angle 8° valgus.



Figure 4. 3rd year postoperatively, anteroposterior/lateral X-ray view of unicompartmental knee arthroplasty with PTS 78°.

DISCUSSION

Although the patient selection process has been shown to be one of the most important factors for obtaining successful outcomes in UKA surgery, there are still some controversial indication criteria.^{9,12,13} Kozin et al. were the first to identify the traditional criteria for such indications. They were limited to the patients with medial osteoarthritis over 60 years old, with a body weight under 82 kg, no anterior knee pain and no arthrosis, except for minimal erosive changes in the patellofemoral region.¹² The indications were then expanded by Berend and Lambordi.¹³ According to these authors, to be eligible for UKA it is sufficient to have posteriorly preserved anterior full-thickness medial cartilage loss, fully correctable varus deformity, full-thickness preserved on the lateral cartilage and a solid anterior cruciate ligament.¹³ The indication criteria of the Oxford Group include knees with medial arthrosis (except inflammatory diseases), a solid anterior cruciate ligament (ACL), flexion contractures under 15 degrees, full-thickness on the lateral cartilage and fully correctable intra-articular varus deformities.⁹ In the present study, the parameters of the Oxford Group were preferred when determining the indications.

The presence of PFA is controversial in the indication criteria. It was a contraindication in previous studies,¹⁴ but in recent publications this is no longer accepted.⁹ In accordance with the current literature, this study shows that PFA does not affect early and mid-term functional outcome of UKA.

Price et al. reported that the 10-year cumulative survival rate in 52 Oxford UKA patients under 60 years of age was not significantly different from that of patients older than 60 years.⁹ In this study, no statistically significant differences were found among age groups. We believe that the UKA is a suitable method for patients of all ages, provided that the indications are met.

In 2013, Murray et al. demonstrated, with multicenter trials, that there is no reduction in survival rates in patients with high BMI values (such as 45-50).¹⁵ In this study, while the functional outcomes of patients who were obese, overweight and had normal weight were excellent, those of morbidly obese patients were significantly lower. We believe that it is not appropriate to perform UKA on morbidly obese patients, although it is possible to achieve excellent results in obese and overweight patients with effective planning and correct surgical techniques.

Most authors believe that valgus overcorrection of the varus deformity is the main cause for lateral arthrosis¹⁶ and some surgeons recommend that the implants should be placed in the minimal varus position, in order to avoid lateral arthrosis.¹⁷ Perkins et al. reported that FTA angles greater than 3° varus and 7° valgus decreased the functional results and increased the revision rate.¹⁸ Consonantly with the literature, in this study the implant placement detected postoperative was 1.5° minor varus. The results were worse in patients whose tibial component position had an angle smaller

than 85° (varus) or bigger than 90° (valgus), while the 85° – 90° TPA groups (normal and minor varus) had excellent results. Furthermore, four out of six patients requiring revision presented TPA disturbances. Bruni et al. found an increase in the PTS in the revised knees of 84 UKA patients, due to spontaneous osteonecrosis, so they recommend the avoidance of PTS overcorrection.¹⁹ All three patients who were diagnosed with PTS misplacement had been submitted to revision. Shakespeare et al. reported that femoral component malalignment did not lead to disorientation in the lower extremity,²⁰ but many publications state that this angular deformity could lead to polyethylene wear.¹⁶ In this study, the group with the femoral component placed more than 10° varus had lower *f*KSS, with a statistically significant difference, and their VAS was significantly higher.

In the Swedish Knee Arthroplasty Register of 2004, which reported a wider number of cases, the most common cause of failure was aseptic loosening of components.⁴ In this study, six (11.5%) patients required revision. For three of them, the reason was the loosening collapse of the tibial and femoral components, while in the other three, it was the tibial loosening and collapse. In five of these cases, what caused the need for revision was incorrect implant positioning, in the case of the other patient, it was caused by morbid obesity (Table 5). Moreover, it was seen that BMI, postoperative TPA and postoperative PTS were the most significant factors that could motivate revision. We found no statistically significant difference between the clinical and radiological outcomes of UKA surgeries performed in the first two years and those of the two subsequent years. However, 60% of the complications and all the revisions occurred during the first two years of UKA surgical experience. This shows the importance of surgical experience.

We understand that the retrospective nature of this study is a limitation. It could be a guide for new surgeons starting to perform UKA surgeries, demonstrating the complications caused by intra-operative eminence fractures, which are not mentioned in the literature. Another factor that attests the value of this study is the insufficient information in the literature about the effect of the PTS angle on implant survival. Multicenter studies should be conducted so that more meaningful results can be obtained, investigating more case series.

CONCLUSION

As the results indicate, implant positioning is a critical factor in the functional outcome and survival rates of UKA. Tibial plateau angle and posterior tibial slope are the radiological parameters that should be particularly considered. In terms of patient selection, UKA is not a suitable option for morbidly obese patients. It may be possible to reduce significantly the revision rates through appropriate patient selection, correct surgical technique and increased surgical experience. If these conditions are met, UKA is a method that can provide excellent results for anteromedial arthrosis in patients of middle and advanced ages.

AUTHORS' CONTRIBUTIONS: Each author contributed individually and significantly to the development of the manuscript. AEP: data collection and analysis and writing of the study; B.PO: surgeries, conceptualization of the study and of the manuscript; TG: surgeries and writing of the study; B.PE: surgeries and revision of the study; TT: surgeries, conceptualization of the study and development of the research project.

REFERENCES

1. Peat G, McCarney R, Croft P. Knee pain and osteoarthritis in older adults: a review of community burden and current use of primary health care. *Ann Rheum Dis.* 2001;60(2):91-7.
2. White SH, Ludkowski PF, Goodfellow JW. Anteromedial osteoarthritis of the knee. *J Bone Joint Surg Br.* 1991;73(4):582-6.
3. Murray DW, Goodfellow JW, O'Connor JJ. The Oxford medial unicompartmental arthroplasty, a ten year survival study. *J Bone Joint Surg Br.* 1998;80(6):983-9.
4. Swedish Knee Arthroplasty Register. Annual Report 2004. Lund; 2004.
5. Chou DT, Swamy GN, Lewis JR, Badhe NP. Revision of failed unicompartmental knee replacement to total knee replacement. *Knee.* 2012;19(4):356-9.
6. O'Connor JJ, Goodfellow JW, Dodd JA, Murray DW. Development and clinical application of meniscal unicompartmental arthroplasty. *Proc Inst Mech Eng H.* 2007;221(1):47-59.
7. Robertsson O, Knutson K, Lewold S, Lidgren L. The routine of surgical management reduces failure after unicompartmental knee arthroplasty. *J Bone Joint Surg Br.* 2001;83(1):45-9.

8. Lyons MC, MacDonald SJ, Somerville LE, Naudie DD, McCalden RW. Unicompartmental versus total knee arthroplasty database analysis: is there a winner? *Clin Orthop Relat Res.* 2012;470(1):84-90.
9. Price AJ, Dodd CA, Svard UG, Murray DW. Oxford medial unicompartmental knee arthroplasty in patients younger and older than 60 years of age. *J Bone Joint Surg Br.* 2005;87(11):1488-92.
10. **Tadros BJ, Dabis J, Twymar R. Short-term outcome of unicompartmental knee arthroplasty in the octogegenerian population. *Knee Surg Sports Traumatol Arthrosc.* 2018;26(5):1571-6.**
11. Pandit HG, Jenkins C, Barker K, Dodd CA, Murray DW. The Oxford medial unicompartmental knee replacement using a minimally-invasive approach. *J Bone Joint Surg Br.* 2006;88(1):54-60.
12. Kozinn SC, Scott R. Unicondylar knee arthroplasty. *J Bone Joint Surg Am.* 1989;71(1):145-50.
13. Berend KR, Lombardi AV Jr. Liberal indications for minimally invasive oxford unicondylar arthroplasty provide rapid functional recovery and pain relief. *Surg Technol Int.* 2007;16:193-7.
14. Goodfellow JW, O'Connor J. Clinical results of the Oxford knee. Surface arthroplasty of the tibiofemoral joint with a meniscal bearing prosthesis. *Clin Orthop Relat Res.* 1986;205:21-42.
15. Murray DW, Pandit H, Weston-Simons JS, Jenkins C, Gill HS, Lombardi AV, et al. Does body mass index affect the outcome of unicompartmental knee replacement? *Knee.* 2013;20(6):461-5.
16. Hernigou P, Deschamps G. Alignment influences wear in the knee after medial unicompartmental arthroplasty. *Clin Orthop Relat Res.* 2004;(423):161-5.
17. **Vasso M, Del Regno C, D'Amelio A, Viggiano D, Corona K, Schiavone Panni A. Minor varus alignment provides better results than neutral alignment in medial UKA. *Knee.* 2015;22(2):117-21.**
18. Perkins TR, Gunckle W. Unicompartmental knee arthroplasty: 3- to 10-year results in a community hospital setting. *J Arthroplasty.* 2002;17(3):293-7.
19. Bruni D, Iacono F. Is unicompartmental arthroplasty an acceptable option for spontaneous osteonecrosis of the knee? *Clin Orthop Relat Res.* 2012;470(5):1442-51.
20. Shakespeare D, Ledger M, Kinzel V. Accuracy of implantation of components in the Oxford knee using the minimally invasive approach. *Knee.* 2005;12(6):405-9.

LATARJET PROCEDURE ON ANTERIOR SHOULDER INSTABILITY IN PROFESSIONAL SOCCER PLAYERS

CIRURGIA DE LATARJET NA INSTABILIDADE ANTERIOR DO OMBRO EM JOGADORES PROFISSIONAIS DE FUTEBOL

GUILHERME AUGUSTO STIRMA¹ , EWERTON BORGES DE SOUZA LIMA¹ , DEGINALDO HOLANDA CHAVES¹ , PAULO SANTORO BELANGERO¹ , CARLOS VICENTE ANDREOLI¹ , BENNO EJNISMAN¹ 

1. Universidade Federal de São Paulo, Paulista Medical School, São Paulo, SP, Brazil.

ABSTRACT

Anterior glenohumeral instability is a frequent cause of professional soccer players' removal, reduced performance, and prolonged recovery. Players are subjected to intense physical contact and high performance, thus demanding lower rates of recurrence after surgical correction so they can return to sport quickly. Objective: To assess professional soccer players treated by the Lartajet technique considering the rate and time of return to sports activities, complications or failures. Methods: Analysis held between 2010 and 2018 of professional soccer players diagnosed with anterior shoulder instability operated by the open procedure of Lartajet in our service. Results: The mean return to professional sports was 93.5 days. The mean time of surgery in relation to the first dislocation was 12.4 months. Each athlete had 4.3 shoulder dislocations until the procedure was performed. The rate of recurrence was zero and subluxation was not observed. Conclusion: The Latarjet procedure allowed all professional athletes to return to competitive activities quickly, without dislocations and subluxation, negative seizure and without complications during follow-up. **Level of evidence IV, Case series.**

Keywords: Anterior Shoulder Instability. Soccer. Shoulder Dislocation.

RESUMO

A instabilidade glenoumeral anterior é uma frequente causa de afastamento dos jogadores de futebol profissional, redução do desempenho e recuperação prolongada. Os jogadores são submetidos ao contato físico intenso e ao alto desempenho, sendo assim necessário atingir menores taxas de recidiva após a correção cirúrgica e retorno ao esporte de forma mais rápida. Objetivo: Avaliar jogadores de futebol profissionais tratados pela técnica de Lartajet com análise da taxa e tempo de retorno às atividades esportivas, complicações ou falhas. Métodos: Análise entre 2010 a 2018 de dez jogadores de futebol que estão atuando em clubes profissionais, diagnosticados por instabilidade anterior do ombro operados pelo procedimento aberto de Lartajet em nosso serviço. Resultados: A média de retorno ao esporte profissional foi de 93,5 dias. A média de tempo da cirurgia em relação ao primeiro episódio de luxação foi de 12,4 meses. Cada atleta teve 4,3 luxações de ombro até o procedimento ser realizado. A taxa de recidivas foi zero e não foi observada subluxação. Conclusão: O procedimento Latarjet propiciou que todos os atletas profissionais de futebol retornassem às atividades competitivas de maneira rápida, sem recidivas das luxações e subluxações e sem complicações durante o acompanhamento realizado. **Nível de evidência IV, Séries de casos.**

Descritores: Instabilidade Anterior do Ombro. Futebol. Luxação do Ombro.

Citation: Stirma GA, Lima EBS, Chaves DH, Belangero PS, Andreoli CV, Ejnisman B. Latarjet procedure on anterior shoulder instability in professional soccer players. *Acta Ortop Bras.* [online]. 2020;28(2):84-7. Available from URL: <http://www.scielo.br/aob>.

INTRODUCTION

Professional soccer athletes present high risk for traumatic shoulder dislocations. Injuries have become a growing problem recently; the physical demands of the game, the higher speed of athletes and muscle strength are reasons that explain the increase in trauma and its associated energy.¹ About 2% of sports injuries in professionals from European teams were linked to the shoulder from 2001 to 2008, but recent studies have shown a total increase of 3.3% and from 35% in the 2006/2007 season to 89% in 2009/2010.²

Anterior glenohumeral instability is a frequent cause of professionals' removal from work, reduced performance and prolonged recovery.³ Several techniques have been proposed to restore stability, function and prevent the development of glenohumeral instability, especially when it comes to athletes with high demand and professionals.⁴ The arthroscopic Bankart repair is a therapeutic option with excellent results in non-athletes but higher failure rates in practitioners of professional contact sports athletes.⁵ Thus, the Latarjet procedure is a viable option for arthroscopic repair failure, in bipolar lesions and when there is a high probability of recurrence.⁶

All authors declare no potencial conflict of interest related to this article.

The study was developed at Universidade Federal de São Paulo (UNIFESP), Department of Orthopedics and Traumatology, Sports Traumatology Center (CETE), São Paulo, SP, Brazil. Correspondence: Guilherme Augusto Stirma. Rua Arruda Alvim, 297, Apartamento 205, São Paulo, SP, Brazil, 05410020. guilhermeaugusto89@hotmail.com



The results of open procedures are higher when compared with the arthroscopic ones in high-risk sports athletes⁷; however, few studies show bone block results related to athletic activity, in this case, soccer. The objective of this study was to assess professional soccer players treated by the Lartajet technique, analyzing the rate and time of return to sports activities, complications or failures.

METHODS

After a retrospective analysis of medical records between 2010 and 2018, professional soccer players diagnosed and followed by anterior shoulder instability who were operated by Lartajet open procedure were evaluated in our service. All patients signed the free and informed consent form, with the number 09628919.2.0000,5505 of the approval by the ethics committee.

The analysis included sex, age, field position, follow-up time, previous surgical procedure on the same shoulder, number of dislocations, time from the first dislocation to surgery, recurrence, complications and time of return to sport.

Patients with multidirectional instability, reparable and irreparable rotator cuff rupture, SLAP, biceps tendon pathology or acromioclavicular joint involvement requiring surgical intervention were not included. The inclusion criteria were: preoperative positive seizure, bipolar injuries, history of dislocations and professional soccer contract.

The surgical Lartajet technique was chosen because of a lower rate of recurrence comparatively with the arthroscopic one in contact sports athletes^{8,9}, patients' profession, bipolar injuries, the surgeon's greater experience and treatment of recurrences by the Bankart repair technique.

The surgery is performed with the patient in a beach chair, access of 6 cm below the coracoid by the axillary line, identification and removal of the cephalic vein, exposure and osteotomy of the coracoid at its base, preparation of the graft with debridement of soft tissues. Horizontal access through the subscapularis and longitudinal muscle of the capsule joint. The debridement and removal of the anteroinferior labrum is performed. The graft is then fixed to the glenoid with two spongy screws of 3.5mm, partial thread with washers (Figures 1 and 2). The subscapularis suture is always lateral to the entry of the conjoint tendon to avoid reduction in lateral rotation.



Figure 1. Postoperative (AP incidence)



Figure 2. Postoperative (scapular profile).

The patients use sling for two weeks. Physical therapy was performed at the institution, going from passive movements to active movements after one month. They performed isometric rotator cuff exercises from the fourth to the sixth week and global isotonic exercises from the fourth-sixth week on, as well as the strengthening of the scapula stabilizers, avoiding carrying weights and lateral rotation with 90°/90° abduction until the eighth week. The evolution is expected to occur from the 4th week up to the 12th week with wide and painless range of motion (ROM). After achieving wide and painless ROM, V strength grade of all intrinsic and extrinsic shoulder muscles, the patient returns to work.

RESULTS

Ten male professional players with a mean age of 22.9 years (ranging from 16 to 28 years) were observed. In three cases (30%) the indication of Lartajet surgery was due to failure in arthroscopic treatment (Bankart repair). The mean of return to sports was 93.5 days, ranging from 60 to 120 days. No acute and chronic complications were observed. No case evolved with positive seizure test in the postoperative period.

The rate of recurrence was zero and subluxation was not observed. In relation to the first dislocation, the mean time of surgery was 12.4 months. Each athlete had 4.3 shoulder dislocations until the procedure was performed. During the follow-up, all patients' motion arc with elevation, abduction, lateral and medial rotation reached the same amplitude. Four (40%) players were strikers, two (20%) were full-backs, two (20%) were defensive midfielders, one (10%) was central-midfielder and one (10%) was defender. The mean follow-up time was 1,251 days. There were no cases of glenohumeral arthrosis (Table 1).

Table 1. Data of the professional athletes.

Sex	Age	Position	Follow-Up	Complications	Return to Sport	Failure	Previous Arthroscopy	First Dislocation-Surgery	Dislocations until Surgery
M	28	Defensive Midfielder	70 months	None	3 months	None	No	24 months	10
M	25	Defender	12 months	None	2 months and 5 days	None	No	1 month	2
M	24	Defensive Midfielder	10 months	None	2 months and 10 days	None	No	2 months	2
M	25	Striker	13 months	None	2 months and 14 days	None	No	6 months	4
M	16	Striker	3 months	None	2 months	None	No	4 months	6
M	26	Central-Midfielder	72 months	None	3 months	None	Yes	24 months	3
M	17	Full-Back	38 months	None	3 months and 10 days	None	Yes	8 months	4
M	27	Striker	58 months	None	3 months and 28 days	None	No	7 months	4
M	22	Striker	52 months	None	4 months	None	No	36 months	6
M	19	Full-Back	72 months	None	4 months and 28 days	None	Yes	12 months	2

DISCUSSION

The current literature shows that professional athletes present a high recurrence after arthroscopic treatment of anterior shoulder instability in contact sports.¹⁰ In our sample, 30% of the patients underwent capsuloplasty, Bankart repair in another service and evolved with failure. Bacilla et al.¹¹ found 10% of the new dislocations with only 18 months of follow-up; however, they were football athletes, and the arthroscopic procedures were performed by the author himself.

The values found for non-athletes cannot be compared with and analyzed for athletes. In initial studies on non-athletes, authors showed high numbers in the failure of arthroscopic Bankart repair, Flinkkila et al.¹⁰ 19%, Voo et al.¹² 18%. However, after the advance of the arthroscopic procedure, some recent cases found similar and even lower values for failure rate. Milchtein et al.¹³ showed 6.4% in contact sports athletes with a return of 82.5% with the same performance level.

For an athlete, being away from sports practice in addition to reduced performance and prolonged recovery can cause devastating effects on their career. Hoveliuss et al.⁸ analyzed, in a comparative study (Lartajet versus Bankart repair), 185 shoulders in which Lartajet presented better postoperative stability and lower complication rates. An et al.⁹, in meta-analysis, described that Lartajet still has lower failure rates and better lateral rotation compared with the Bankart repair.⁹ Although the arthroscopic Bankart repair shows similar comparative values of relaxations in some case series, Lartajet still contains better clinical results and lower dislocation and subluxation rates after long-term follow-up, and it offers greater safety for athletes to resume their activities.^{4,3,13,14}

For strikers, central-midfielders, defenders and full-backs, the instability can cause major problems for their careers. The residual pain, ROM loss and positive seizure are factors that can lead to fear of new dislocations due to falls and physical contact, reduced professional performance and inefficiency in throw-ins. Ekstrand et al.¹⁵ reported that shoulder dislocation represents the most serious upper limb injury in soccer, with an average leave time of 41 days. They have shown that the absence of training and games is twice higher for goalkeepers than for field players due to throw-ins, direct and indirect shoulder traumas for falls and defenses. The injuries in the upper limb in goalkeepers can reach frequent values up to 5x more, compared with other soccer positions.¹

Although this study is unique and the results differ from those of Cerciello et al.³ who studied 28 professional goalkeepers treated surgically and observed a 12.5% rate of recurrence, other analyses were verified with contact athletes, in which case series respect and match our low failure rate after the open Lartajet

procedure.^{11,15} Privitera et al.⁵ described 8% and 14% of patients with postoperative instability perception (positive seizure), but without dislocation; however, from the cases analyzed, only six (8%) were soccer players.

Neyton et al. in a 12-year follow-up after the surgical procedure in Rugby players did not find subluxation or anterior glenohumeral dislocation.¹⁶

In relation to the first dislocation, the mean time of surgery was 12.4 months. Each athlete had 4.3 shoulder dislocations until the procedure was performed. Cerciello et al.³ showed that the goalkeepers waited 2.2 dislocations, since they rely more on their shoulder than strikers, mid-fielders, defenders and full-backs present in our study and cannot wait to undergo surgery after the soccer season.

Positive seizure in the postoperative clinical evaluation was not obtained. Neyton et al. found 14% in rugby players through the Lartajet procedure.¹⁶

The mean time of return to sport was 93.5 days, with 100% return of players. Hart and Funk¹⁷ after the treatment of 25 soccer players by arthroscopic technique and five by Latarjet surgery returned to the fields after 81.9 days, on average, with no significant difference between goalkeepers and field players and without recurrences after 91 weeks of follow-up. Cerciello et al.³ reported excellent results for bone block (Latarjet) in a sample of 26 soccer players (28 shoulders). Only one player did not return to soccer. The mean return time was longer than in our study, 150 days. Eighteen players (20 shoulders, 71% of cases) returned to the same level. A goalkeeper suffered a recurrence 74 months after surgery.³

In comparison with other sports, we obtained a superior percentage of return to sports. Neyton et al.¹⁶ showed that Rugby players reached 67%, Bonneville et al.¹⁶ 97%, and Larrain et al.¹⁸ 84%. Privitera et al.⁵ obtained 72% return to activities, 63% at the same previous competitive level; however, the sample of the study consisted of higher-risk sports (football, hockey, skiing, snowboarding, martial arts, wrestling, boxing).

It is of paramount importance to highlight the success of the Lartajet procedure in high-performance athletes, not only due to early functional improvement, lower chance of postoperative seizure, but because they are submitted to early return to professional activities, small rest time between games, intense physical contact, need to return early to high performance level and due to lower rates of recurrence.

This study has some limitations, because it is a retrospective analysis, a unique surgical technique. Only 10 patients were studied, but it is noteworthy that they are professional athletes with long follow-up time.

CONCLUSION

This study showed that the Latarjet procedure in the treatment of recurrent anterior instability in professional soccer players is

effective. The Latarjet procedure allowed all professional athletes to return to sports quickly, without dislocations and subluxation, negative seizure and no complications during the follow-up.

AUTHORS' CONTRIBUTIONS: Each author contributed individually and significantly to the development of this article. GAS: authorship, writing, review, intellectual concept of the article and preparation of the entire research project. EBSL: authorship, writing, review and intellectual concept of the article; DHC: authorship, writing, review and intellectual concept of the article; PSB: authorship and review of the article; CVA: authorship, writing, review and intellectual concept of the article; BE: authorship, writing, review and intellectual concept of the article.

REFERENCES

1. Marom N, Williams RJ 3rd. Upper extremity injuries in soccer. *Am J Orthop (Belle Mead NJ)*. 2018;47(10):1-10.
2. Ekstrand J, Häggglund M, Waldén M. Injury incidence and injury patterns in professional football: The UEFA injury study. *Br J Sports Med*, 2011;45(7):553-8.
3. Cerciello S, Edwards T B, Walch G. Chronic anterior glenohumeral instability in soccer players: results for a series of 28 shoulders treated with the Latarjet procedure. *J Orthop Traumatol*, 2012;13(4):197-202.
4. Beranger JS, Klouche S, Bauer T, Demoures T, Hardy P. Anterior shoulder stabilization by Bristow–Latarjet procedure in athletes: return-to-sport and functional outcomes at minimum 2-year follow-up. *Eur J Orthop Surg Traumatol*. 2016;26(3):277-82.
5. Privitera DM, Sinz N, Miller L, Siegel E, Solberg M, Daniels S, Higgins L. Clinical outcomes following the Latarjet procedure in contact and collision athletes. *J Bone Joint Surg Am*. 2018;100(6):459-65.
6. Balg F, Boileau P. The instability severity index score: a simple pre-operative score to select patients for arthroscopic or open shoulder stabilisation. *J Bone Joint Surg Br*. 2007 ;89(11):14707.
7. Pillai G, Baynes JR, Gladstone J, Flatow EL. Greater strength increase with cyst decompression and SLAP repair than SLAP repair alone. *Clin Orthop Relat Res*. 2011;469(4):1056-60.
8. Hovelius L, Vikersjö O, Olofsson A, Svensson O, Rahme H. Bristow-Latarjet and Bankart: a comparative study of shoulder stabilization in 185 shoulders during a seventeen-year follow-up. *J Shoulder Elbow Surg*. 2011;20(7):1095-101.
9. An VVG, Sivakumar BS, Phan K, Trantalis J. A systematic review and meta-analysis of clinical and patient-reported outcomes following two procedures for recurrent traumatic anterior instability of the shoulder: Latarjet procedure vs. Bankart repair. *J Shoulder Elbow Surg*. 2016;25(5):853-63.
10. Flinckilä T, Hyvönen P, Ohtonen P, Leppilähti J. Arthroscopic Bankart repair: Results and risk factors of recurrence of instability. *Knee Surg Sports Traumatol Arthrosc*, 2013;18(12):1752-8.
11. Bacilla P, Field LD, Savoie FH III. Arthroscopic bankart repair in a high demand patient population, 2009;13(1):202-7.
12. Voos JE, Livermore RW, Feeley BT, Altchek DW, Williams RJ, Warren RF, et al. Prospective evaluation of arthroscopic bankart repairs for anterior instability. *Am J Sports Med*. 2010;38(2):302-7.
13. Milchtein C, Tucker SA, Nye DD, Lamour RJ, Liu W, Andrews JR, Ostrander RV. Outcomes of bankart repairs using modern arthroscopic technique in an athletic population. *Arthroscopy*. 2016;32(7):1263-70.
14. Grana WA, Buckley PD, Yates CK. Arthroscopic Bankart suture repair. *Am J Sports Med*. 1993;21(3):348-53.
15. Ekstrand J, Häggglund M, Törnqvist H, Kristenson K, Bengtsson H, Magnusson H, Waldén M. Upper extremity injuries in male elite football players. *Knee Surg Sports Traumatol Arthrosc*, 2013;21(7):1626-32.
16. Neyton L, Young A, Dawidziak B, Visona E, Hager JP, Fournier Y, Walch G. Surgical treatment of anterior instability in rugby union players: clinical and radiographic results of the Latarjet-Patte procedure with minimum 5-year follow-up. *J Shoulder Elbow Surg*, 2012;21(12):1721-7.
17. Hart D, Funk L. Serious shoulder injuries in professional soccer: return to participation after surgery. *Knee Surg Sports Traumatol Arthrosc*, 2015;23(7):2123-9.
18. Larrain MV, Montenegro HJ, Mauas DM, Collazo CC, Pavón F. Arthroscopic management of traumatic anterior shoulder instability in collision athletes: analysis of 204 cases with a 4- to 9-year follow-up and results with the suture anchor technique. *Arthroscopy*. 2006;22(12):1283-9.

TREATMENT OF MIDSHAFT CLAVICLE FRACTURE WITH SUPERIOR PLATE PLACEMENT

TRATAMENTO PARA FRATURA DA DIÁFISE DA CLAVÍCULA COM INSERÇÃO DE PLACA ÓSSEA SUPERIOR

BEKIR ERAY KILINC¹ , YUNUS Oc² , RAMAZAN ERDEN ERTURER³ 

1. Health Science University, Fatih Sultan Mehmet Training and Research Hospital, Orthopaedics Department, Istanbul, Turkey.

2. Health Science University, Sisli Hamidiye Training and Research Hospital, Orthopaedics Department, Istanbul, Turkey.

3. Istinye University, Faculty of Medicine, Orthopaedics Department, Istanbul, Turkey.

ABSTRACT

Objective: To evaluate the late clinical and radiological results of patients had locking plate anatomically compatible from superior surface and muscle cover on plate due to clavicle mid-region. **Materials and Methods:** Forty patients were included retrospectively. Patients had a routine right shoulder anterior posterior graph after examination. The results were assessed by returning to the patient's daily activities, Constant score, the Disability of the Arm, and Shoulder and Hand scoring, followed by radiological and clinical examination. **Results:** Fourteen (35%) patients were female and 26 (65%) were male. The mean age was 36.2 years. Twenty-six patients had right clavicle fracture and 14 patients had left. Twenty-three fractures were type 2B1 and 17 fractures were type 2B2. Mean follow-up time was 36.4 months. Radiologic union was at a mean of 9.1 ± 1.3 weeks. All patients had excellent results. The mean Constant score was 97.2 ± 1.8 , the mean Disability of the Arm, and Shoulder and Hand score was 3.8 ± 2.4 . **Conclusion:** It is possible to obtain complete union with high patient satisfaction by avoiding the complications and difficulties of the conservative treatment with the use of the anatomically compatible locking plates in superior fixation and our surgical dissection. **Level of Evidence III, Retrospective Case controlled study.**

Keywords: Clavicle. Midshaft Clavicle Fracture. Osteosynthesis. Plate Fixation. Superior Placement.

RESUMO

Objetivo: Avaliar os resultados clínicos e radiológicos tardios dos pacientes com placa óssea de trava anatomicamente compatível com a superfície superior e a cobertura muscular na placa devido à região média da clavícula. **Materiais e Métodos:** Quarenta pacientes foram incluídos retrospectivamente. Os pacientes apresentaram um gráfico ântero-posterior de rotina do ombro direito após o exame. Os resultados foram avaliados retornando às atividades diárias do paciente, escore de Constant, incapacidade do braço e escores de ombro e mão, seguidos de exame clínico e radiológico. **Resultados:** Quatorze (35%) pacientes eram do sexo feminino e 26 (65%) do sexo masculino. A idade média foi de 36,2 anos. Vinte e seis pacientes tiveram fratura da clavícula direita e 14 pacientes saíram. Vinte e três fraturas foram do tipo 2B1 e 17 fraturas do tipo 2B2. O tempo médio de acompanhamento foi de 36,4 meses. A união radiológica foi em média de $9,1 \pm 1,3$ semanas. Todos os pacientes tiveram excelentes resultados. A pontuação média constante foi de $97,2 \pm 1,8$, a média de incapacidade do braço e a pontuação do ombro e da mão foi de $3,8 \pm 2,4$. **Conclusão:** É possível obter união completa com alta satisfação do paciente, evitando as complicações e dificuldades do tratamento conservador com o uso das placas ósseas de trava anatomicamente compatíveis na fixação superior e na nossa dissecação cirúrgica. **Nível de evidência III, Estudo retrospectivo controlado por caso.**

Descritores: Clavícula. Fratura de Clavícula de Eixo Intermediário. Fixação de Placas Ósseas. Colocação Superior.

Citation: Kilinc BE, Oc Y, Erture RE. Treatment of midshaft clavicle fracture with superior plate placement. Acta Ortop Bras. [online]. 2020;28(2):88-91. Available from URL: <http://www.scielo.br/aob>.

INTRODUCTION

Clavicle fracture is a common fracture and constitutes approximately 4% of all fractures in adults.¹ The location of the clavicle fracture is approximately 75% clavicular and 1/3 middle part due to its thin form and direct contact with the skin. Clavicular injuries can lead to abnormal biomechanical stresses and long-term disability along the pectoral girdle.^{2,3}

Conservative treatment and open reduction and plate fixation are used in the treatment of the currently displaced midshaft clavicle fractures. Conservative treatment was reported to have a higher union rate than open reduction and plate fixation.⁴ However, patients treated with open reduction and plate fixation have a better outcome than conservative treatments according to functional scores.⁵ Despite the reduced pain and improved

All authors declare no potential conflict of interest related to this article.

Correspondence: Bekir Eray Kilinc. Icerenkoy District Zubeyde Hanım Street N°: 1 B-43 PC:43752 Atasehir/Istanbul Tel n°: +905306061884. dreraykilinc@gmail.com
The study was carried out at Istinye University.

Article received on 7/16/2019, approved on 10/10/2019.

functional recovery in patients with displaced midclavicular fractures treated with open reduction and plate fixation,^{6,7} infection due to the graft of a large soft tissue can lead to complications such as numbness on the skin, nonunion, delayed union, and enlarged scar tissue.⁸⁻¹⁰

Treatment of these fractures with open reduction and internal fixation preserves from nonunion, symptomatic malunion, shortening and deformity. Studies have shown that the superior plate is biomechanically better than the anterior plate and that the locked screws are better than the unlocked ones.¹¹⁻¹³ But superior resident plates are usually palpable under the skin and can cause skin irritation.¹⁴⁻¹⁹

In this study, we sought to evaluate the late clinical and radiological results of patients who underwent locking plate fixation anatomically compatible in the superior surface and muscle cover on plate due to the mid-region of the clavicle.

METHODS

Forty patients who underwent surgery between May 2009 and September 2016 with mid-diaphyseal clavicle fracture were included retrospectively in our study. All patients participating in the study signed an informed consent form. The study was conducted in agreement with the Declaration of Helsinki. Approval for our study was obtained from the institutional review board. Our study is in line with the STROCSS criteria. Displacement or shortness of more than 20 mm in patients with segmental fractures with multiple fractures or disintegration, as well as conservative treatment intolerance were indicated for surgical treatment. The study included only patients with isolated mid-diaphyseal clavicle fractures.²⁰ Patients with pathologic fractures, open fractures, those with neurovascular injuries and/ or 2-week fractures were excluded. All patients had chest radiography to exclude possible cote and scapular injury. After diagnosis, patients were prepared for surgery by applying a shoulder-arm sling.

All patients were assessed with a routine right-shoulder anterior-posterior graph after a detailed physical examination. During the follow-up period, the results were clinically assessed by the patient's return to daily activities, Constant score, the Disability of the Arm, and Shoulder and Hand scoring, followed by radiological and clinical examination of the fracture union.

Surgical Technique

Patients were prepared for operation in beach-chair position under general or regional anesthesia. Skin incision was made approximately 1 cm below the clavicle lower level (infraclavicular incision). The subcutaneous tissue was prepared without dissecting, and the preparation of skin-subcutaneous and platysma muscle together in a flap style, clavicle anterior and superior sides were elevated by approaching to proximal. Thus, the clavipectoral fascia was scrapped over the clavicle to the extent that was required and the fraction was reduced by avoiding an aggressive dissection. Temporary detection with K-wires was performed when necessary. In the case of the butterfly fragment, these fragments were temporarily attached to the main part with absorbable sutures (Vicryl no: 0). Rigid fixation by applying a 3.5 mm locking screw (LCP Superior Anterior Clavicle Plate) and a preformed clavicle plate with a low contact surface were performed for the all patients. At the end of the operation, clavipectoral fascia was repaired to cover the plate. Flap prepared initially from skin-subcutaneous and muscle, was completely closed on the plate in such a way that it was completely muscular (Figure 1).

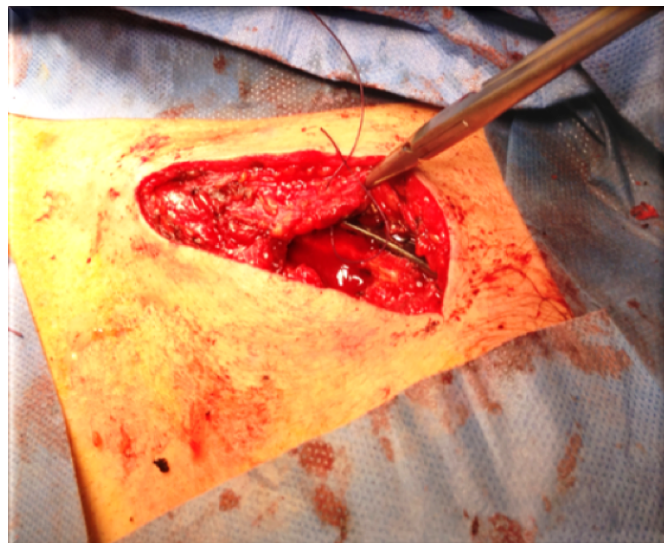

Figure 1. Muscular flap.

Post-operative protocol

Shoulder pendular exercises were started for patients on the first day after the surgery. Antibiotic prophylaxis continued for 2 days after the operation. Surgical wound was checked on the 3rd day, and the patients were discharged with arm sling. Patients were called for control at 4, 8 and 12 weeks postoperatively. In the fourth week, exercises of the shoulder joint movement were started when the use of the arm sling were interrupted. The radiologic examinations required to evaluate the postoperative fracture were examined by an orthopedic surgeon and a radiologist blinded for the study. Radiographically, more than 50% of the fracture lines were classified as complete union. Union was assessed by bone bridge formation between fracture fragments, sensitivity on the fracture line and clinical examination of the shoulder joint movements. The delayed union was determined by the initial radiologic callus formation that was seen after 24 weeks, and the nonunion was determined by the absence of callus and pathological movement after 24 weeks.²¹ Shoulder strengthening exercises have been initiated for patients that had union symptoms. Contact sports were allowed three months after the surgery.

NCSS 2007 version software (Number Cruncher Statistical System – Kaysville, Utah, USA) was used for the statistical analysis. While evaluating the data from the study, apart from using descriptive statistical methods (Mean, Standard Deviation, Median, Frequency, Rate, Minimum, Maximum), Mann Whitney U test was used for the two group comparison for the parameters with abnormal distribution. Fisher-Freeman-Halton test, Fisher's Exact test and Yates' Continuity Correction test (Yates' correction chi square) were used to compare qualitative data. Wilcoxon Signed Ranks test was used for intra-group comparisons of abnormal parameters. Significance was evaluated considering $p < 0.05$.

RESULTS

In total, 14 patients (35%) were women and 26 were men (65%). The mean age of the patients participating in the study was 36.2 (range: 22-59). Twenty-six patients had clavicle fracture on the right side and 14 patients, on the left side. According to Robinson's classification, 23 fractures were type 2B1 and 17 fractures were type 2B2. Mean

follow-up time was 36.4 months (range: 24-95). Fractures occurred in 20 patients due to traffic accidents, in 11 patients due to falls and in 9 patients due to sports injuries, as shown in Table 1.

Characteristic	Total	%
Sex		
Women	14	35
Men	26	65
Age	36.2	
Side		
Right	26	65
Left	14	35
Fracture type		
Type 2B1	23	57.5
Type 2B2	17	42.5
Injury mechanism		
Traffic Accident	20	50
Fall	11	27.5
Sports Injury	9	22.5

Radiologic complete union was achieved in all patients at a mean of 9.1 ± 1.3 weeks, (range: 8-13 weeks). No callus formation was observed in the fracture area of any patient. No complications such as infection or detection failure were found in the early or late period. In total, two patients described the feeling of irritation due to the plate and 7 patients were cosmetically disturbed by the incision scar. None of the patients had major complications such as infection, plate rupture or neurovascular injury. All patients reported excellent results in terms of shoulder functions. At the end of the follow-up period, the mean Constant score was found to be 97.2 ± 1.8 (range: 95-100), mean Disability of the Arm, Shoulder and Hand score was 3.8 ± 2.4 (range: 0-10), as shown in Table 2. The mean duration of the surgery was 52.2 minutes.

Outcome score	Post-operative
Constant score	97.2
Disability of the Arm, Shoulder and Hand scoring	3.8

DISCUSSION

Numerous studies seeking an optimal treatment in the treatment of mid-diaphyseal clavicle fractures have been increasingly conducted. Mid-diaphyseal clavicle fractures were traditionally treated conservatively; however, recent studies show that nonunion, malunion, and poor shoulder functions are seen together with conservative treatment of displaced mid-diaphyseal fractures. In a comparative study between plate-treated and conservatively treated displaced mid-diaphyseal fractures, high functional outcomes, low nonunion and malunion results were found in patients treated surgically.²² Patients treated with plate fixation recovered faster and returned to their previous activity levels, and a risk of developing a symptomatic malunion was reported in conservatively-treated patients. Many other studies also suggest open reduction and fixation in the treatment of displaced mid-diaphyseal fractures, particularly those with 20 mm shortening, 100% displacement and bone defect.²³⁻²⁵ Despite the good stability, compression and mechanical fixation with plate fixation, complications such as infection and formation of scar tissue were found. Although the clavicle fixation as an

intramedullary is cosmetically acceptable, complications rates of up to 75% were reported, namely lack of rotational control, the need for a second surgical procedure to remove the implant, skin problems, and implant migration.^{6,26-28}

Optimal plate fixation for the treatment of mid-diaphyseal clavicle fracture is still controversial. Some studies suggest that anteroinferior plate fixation techniques are better, suggesting that plate prominence is felt less often. However, more soft tissue dissection is required for this plate fixation. In the same study, the authors suggested that the lateral bearing of the plate fixation point and the lateral screws could cause a pull-out in the placement of the superiorly positioned plate in fragmented fractures.²⁹ This is the reason why the fixation due to an unsuccessful reduction was reported as a posterior slide of the support point and a significant force to the lateral load, causing the pull-out of the screws. The sternoclavicular joint created a tension band effect and the support point remained at the fracture fixation point in simple transverse fractures.³⁰ In our study, 17 patients with Robinson type B2 (partial fracture) had no complications due to plate placement, which can be considered a result of the suitability of the reduction, plate fixation and fixation method for the stabilization rules, as shown in Figure 2.

In an anatomical study, the subclavian artery in the medial half of the clavicle was the closest to the posterior cortex.^{31,32} This is the reason why anteroinferior plate fixation can pose a great risk for neurovascular structures in the medial clavicular area. This may be considered a safe fixation method due to the reduction in the risk of a neurovascular injury caused by superior plate detection. Neurovascular injury or other major complications were not detected in any of our patients in our study when super anatomical plate detection was used in surgical treatment.

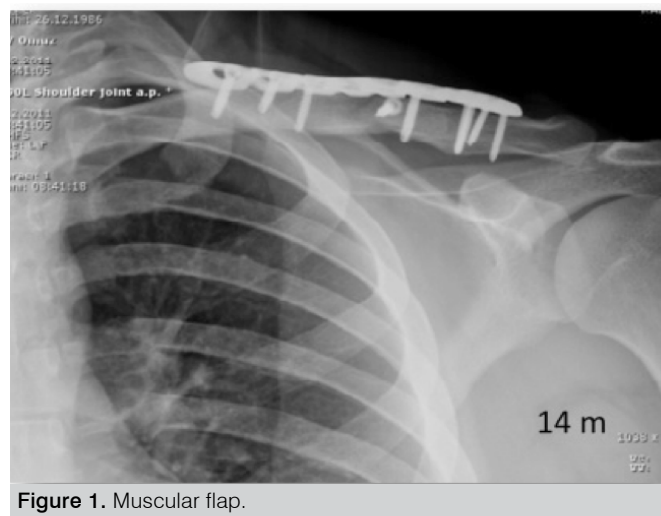

Figure 1. Muscular flap.

A previous study showed that the use of locked plate-screw in fragmented clavicle fractures increased the angular stability and decreased the effect on the bio-alloying of small fractures.^{21,33} Clinically, plate prominence inferiority due to low profile of anatomically compatible plate in mid-diaphyseal clavicle fractures is low.³⁴ We also think that the use of preformed anatomically compatible plates in our study reduces the duration of surgery and plate tiredness risk. At the same time, without applying subcutaneous dissection after surgical incision, the approach that we provide as flap with the plate scar can provide a good cover after plate fixation and reduce plate prominence risk.

In a study conducted biomechanically, the anterior, antero-superior, and superior plating types were found to be the most important

method for detecting axial fracture of superior plate in the detection of midshaft clavicle fractures. In the same study, no difference was found between torsional forces and resistance among all three types of plate fixation.³⁵

Our study has some limitations. First, the study retrospective design was the main limitation, and we also included patients with wide range of age distribution. However, we included similar type of fracture and treated our patients with the same method. Our study may guide further studies on the evaluation of the superior plating treatment due to the clinical outcomes found.

We believe we have achieved excellent results with our study on the fixation of the fracture with our superior plate fixation technique

and with an early rehabilitation program applied to all patients. Furthermore, we think that we can minimize the plate prominence risk by providing the muscle flap and plate covering that we used during the surgical approach and adapt the patients to the rehabilitation period, minimizing the complaints of skin irritation in later periods.

CONCLUSION

Complications such as shortening and excessive callus formation can be observed as a result of disintegrated or multi-part midshaft clavicle fractures. It is possible to obtain complete union with high patient satisfaction by avoiding the complications with anatomically compatible locking plates in superior fixation and our surgical dissection.

AUTHORS' CONTRIBUTIONS: Each author made significant individual contributions to this manuscript. BEK: substantial contributions to the conception and design of the study; YO: data acquisition, analysis, and interpretation; REE: final approval of the version to be published and accountability for all aspects of the study, ensuring that questions related to the accuracy or integrity of any part of the article are appropriately investigated and resolved.

REFERENCES

1. Nowak J, Mallmin H, Larsson S. The aetiology and epidemiology of clavicular fractures: a prospective study during a two-year period in Uppsala, Sweden. *Injury*. 2000;31(5):353-8.
2. Hillen RJ, Burger BJ, Pöhl RG, van Dijk CN, Veeger DH. The effect of experimental shortening of the clavicle on shoulder kinematics. *Clin Biomech*. 2012;27(8):777-81.
3. Matsumura N, Ikegami H, Nakamichi N, Nakamura T, Nagura T, Imanishi N, et al. Effect of shortening deformity of the clavicle on scapular kinematics: a cadaveric study. *Am J Sports Med*. 2010;38(5):1000-6.
4. Robinson CM, Goudie EB, Murray IR, Jenkins PJ, Ahktar MA, Read EO, et al. Open reduction and plate fixation versus nonoperative treatment for displaced midshaft clavicular fractures: a multicenter, randomized, controlled trial. *J Bone Joint Surg Am*. 2013;95(17):1576-84.
5. McKee RC, Whelan DB, Schemitsch EH, McKee MD. Operative versus nonoperative care of displaced midshaft clavicular fractures: a meta-analysis of randomized clinical trials. *J Bone Joint Surg Am*. 2012;94(8):675-84.
6. Zlowodzki M, Zelle BA, Cole PA, Jeray K, McKee. Treatment of acute midshaft clavicle fractures: systematic review of 2144 fractures: on behalf of the Evidence-Based Orthopaedic Trauma Working Group. *J Orthop Trauma*. 2005;19(7):504-7.
7. Rudzki JR, Matava MJ, Paletta GA Jr. Complications of treatment of acromioclavicular and sternoclavicular joint injuries. *Clin Sports Med*. 2003;22(2):387-406.
8. D'Heurle A, Le T, Grawe B, Casstevens EC, Edgington J, Archdeacon MT, et al. Perioperative risks associated with the operative treatment of clavicle fractures. *Injury*. 2013;44(11):1579-81.
9. Jeong HS, Park KJ, Kil KM, Chong S, Eun HJ, Lee TS, et al. Minimally invasive plate osteosynthesis using 3D printing for shaft fractures of clavicles: technical note. *Arch Orthop Trauma Surg*. 2014;134(11):1551-5.
10. Sohn HS, Kim BY, Shin SJ. A surgical technique for minimally invasive plate osteosynthesis of clavicular midshaft fractures. *J Orthop Trauma*. 2013;27(4):92-6.
11. Celestre P, Roberston C, Mahar A, Oka R, Meunier M, Schwartz A. Biomechanical evaluation of clavicle fracture plating techniques: does a locking plate provide improved stability? *J Orthop Trauma*. 2008;22(4):241-7.
12. Partal G, Meyers KN, Sama N, Pagenkopf E, Lewis PB, Goldman A, et al. Superior versus anteroinferior plating of the clavicle revisited: a mechanical study. *J Orthop Trauma*. 2010;24(7):420-5.
13. Robertson C, Celestre P, Mahar A, Schwartz A. Reconstruction plates for stabilization of mid-shaft clavicle fractures: differences between nonlocked and locked plates in two different positions. *J Shoulder Elbow Surg*. 2009;18(2):204-9.
14. Chen CH, Chen JC, Wang C, Tien YC, Chang JK, Hung SH. Semitubular plates for acutely displaced midclavicular fractures: a retrospective study of 111 patients followed for 2.5 to 6 years. *J Orthop Trauma*. 2008;22(7):463-6.
15. Court-Brown CM, Caesar B. Epidemiology of adult fractures: a review. *Injury*. 2006;37(8):691-7.
16. Demirhan M, Bilsel K, Atalar AC, Bozdag E, Sunbuloglu E, Kale A. Biomechanical comparison of fixation techniques in midshaft clavicular fractures. *J Orthop Trauma*. 2011;25(5):272-8.
17. Eden L, Doht S, Frey SP, Ziegler D, Stoyhe J, Fehske K, et al. Biomechanical comparison of the locking compression superior anterior clavicle plate with seven and ten hole reconstruction plates in midshaft clavicle fracture stabilization. *Int Orthop*. 2012;36(12):2537-43.
18. Ferran NA, Hodgson P, Vannet N, Williams R, Evans RO. Locked intramedullary fixation vs plating for displaced and shortened mid-shaft clavicle fractures: a randomized clinical trial. *J Shoulder Elbow Surg*. 2010;19(6):783-9.
19. Formaini N, Taylor BC, Backes J, Bramwell TJ. Superior versus anteroinferior plating of clavicle fractures. *Orthopedics*. 2013;36(7):e898-904.
20. Agha RA, Borrelli MR, Vella-Baldacchino M, Thavayogan R, Orgill DP; STROCCS Group. The STROCCS statement: strengthening the reporting of cohort studies in surgery. *Int J Surg*. 2017;46:198-202.
21. Ozler T, Guven M, Kocadal AO, Ulucay C, Beyzadeoglu T, Altintas, F. Locked anatomic plate fixation in displaced clavicular fractures. *Acta Orthop Traumatol Turc*. 2012;46(4):237-42.
22. Altamimi SA, McKee MD. Nonoperative treatment compared with plate fixation of displaced midshaft clavicular fractures. Surgical technique. *J Bone Joint Surg Am*. 2008;90(Suppl 2 Pt 1):1-8.
23. Jorgensen A, Troelsen A, Ban I. Predictors associated with nonunion and symptomatic malunion following non-operative treatment of displaced midshaft clavicle fractures: a systematic review of the literature. *Int Orthop*. 2014;38(12):2543-9.
24. Lai YC, Tarng YW, Hsu CJ, Chang WN, Yang SW, Renn JH. Comparison of dynamic and locked compression plates for treating midshaft clavicle fractures. *Orthopedics*. 2012;35(5):e697-702.
25. Rehn CH, Kirkegaard M, Viberg B, Larsen MS. Operative versus nonoperative treatment of displaced midshaft clavicle fractures in adults: a systematic review. *Eur J Orthop Surg Traumatol*. 2014;24(7):1047-53.
26. Renfree T, Conrad B, Wright T. Biomechanical comparison of contemporary clavicle fixation devices. *J Hand Surg Am*. 2010;35(4):639-44.
27. Judd DB, Pallis MP, Smith E, Bottoni CR. Acute operative stabilization versus nonoperative management of clavicle fractures. *Am J Orthop*. 2009;38(7):341-5.
28. Smekal V, Irenberger A, Struve P, Wambacher M, Krappinger D, Kralinger FS. Elastic stable intramedullary nailing versus nonoperative treatment of displaced midshaft clavicular fractures—a randomized, controlled, clinical trial. *J Orthop Trauma*. 2009;23(2):106-12.
29. Favre P, Kloen P, Helfert DL, Werner CM. Superior versus anteroinferior plating of the clavicle: a finite element study. *J Orthop Trauma*. 2011;25(11):661-5.
30. Basamania CJ, Rockwood CA. Fractures of the clavicle. In: Rockwood CA, editor. *The shoulder*. 4th ed. Philadelphia: WB Saunders; 2008. p. 423-8.
31. Lo EY, Eastman J, Tseng S, Lee MA, Yoo BJ. Neurovascular risks of anteroinferior clavicular plating. *Orthopedics*. 2010;33(1):21.
32. Robinson L, Persico F, Lorenz E, Seligson D. Clavicular caution: an anatomic study of neurovascular structures. *Injury*. 2014;45(12):1867-9.
33. 33. Gautier E, Sommer C. Guidelines for the clinical application of the LCP. *Injury*. 2003;34(Suppl 2):B63-76.
34. 34. VanBeek C, Boselli KJ, Cadet ER, Ahmad CS, Levine WN. Precontoured plating of clavicle fractures: decreased hardware-related complications? *Clin Orthop Relat Res*. 2011;469(12):3337-43.
35. Huang TL, Chen WC, Lin KJ, Tsai CL, Lin KP, Wei HW. Conceptual finite element study for comparison among superior, anterior, and spiral clavicle plate fixations for midshaft clavicle fracture. *Med Eng Phys*. 2016;38(10):1070-5.

CHANGES IN THE LUMBAR VERTEBRAL SEGMENT RELATED TO THE CAGE POSITION IN TLIF TECHNIQUE

ALTERAÇÕES DO SEGMENTO VERTEBRAL LOMBAR RELACIONADAS À POSIÇÃO DO CAGE NO TLIF

THIAGO DANTAS MATOS¹ , RODRIGO BARRA CAIADO FLEURY¹ , KELSEN DE OLIVEIRA TEIXEIRA¹ , VALÉRIA ROMERO² , HELTON LUIZ APARECIDO DEFINO¹ 

1. Universidade de São Paulo, Faculdade de Medicina de Ribeirão Preto, Departamento de Cirurgia Ortopedia e Traumatologia, Ribeirão Preto, SP, Brazil.
2. Universidade Estadual de Campinas, Medical School, Campinas, SP, Brazil.

ABSTRACT

Objective: To evaluate the morphological changes on the intervertebral foramen and segmental lordosis related to the transforaminal lumbar interbody fusion (TLIF) positioning. **Methods:** PEEK cages were placed in the disc space (L1-S1) of a polyurethane anatomical model. Cages of different heights (8 mm, 10 mm, 12 mm and 14 mm) were positioned in the posterior, medial or anterior part of the vertebral body surface, and the intervertebral foramen and segmental lordosis heights were measured after their insertion. **Results:** The vertebral foramen height decreased in all positions and heights of the cages in relation to the control. The cage posterior positioning induced a smaller reduction in the vertebral foramen height. Vertebral lordosis tended to increase in relation to the control, and the greatest increase occurred with the cage posterior positioning. **Conclusion:** Cage positioning induces changes in the intervertebral foramen height and in the vertebral segment lordosis. Cage posterior positioning induces a smaller reduction of the intervertebral foramen height and increases the vertebral segment lordosis. **Level of evidence III, Therapeutic study.**

Keywords: Spine. Arthrodesis. Biomechanical Phenomena.

RESUMO

Objetivo: Avaliar as alterações morfológicas do forâmen intervertebral e da lordose segmentar relacionadas ao posicionamento do espaçador intersomático na artrodese lombar intersomática transforaminal (TLIF). **Métodos:** Cages de PEEK foram colocados no espaço discal (L1-S1) de modelo anômico de poliuretano. Os cages de diferentes alturas (8 mm, 10 mm, 12 mm e 14 mm) foram posicionados na parte posterior, média ou anterior da superfície do corpo vertebral e a altura do forame intervertebral e lordose segmentar mensuradas após a sua inserção. **Resultados:** Foi observado redução da altura do forame vertebral em todos os posicionamentos e alturas dos cages em relação ao controle. O posicionamento posterior do Cage induziu à menor redução da altura do forame vertebral. A lordose do segmento vertebral apresentou tendência de aumento em relação ao controle, tendo sido observado a maior tendência com o posicionamento posterior do Cage. **Conclusão:** O posicionamento do Cage induz a alterações da altura do forame intervertebral e lordose do segmento vertebral. O posicionamento posterior do Cage induz a menor redução da altura do forame intervertebral e aumento da lordose do segmento vertebral. **Nível de evidência III, Estudo terapêutico.**

Descritores: Coluna Vertebral. Artrodese. Fenômenos Biomecânicos.

Citation: Matos TD, Fleury RBC, Teixeira KO, Romero V, Defino HLA. Changes in the lumbar vertebral segment related to the cage position in TLIF technique. Acta Ortop Bras. [online]. 2020;28(2):92-6. Available from URL: <http://www.scielo.br/aob>.

INTRODUCTION

Transforaminal lumbar interbody fusion (TLIF) has been widely used for the treatment of diseases affecting the lumbar spine, especially degenerative diseases.¹⁻³ Restoration or maintenance of the vertebral segment lordosis has guided surgical treatment due to its influence on clinical outcomes.³⁻⁶ Design and positioning

of the vertebral spacers used in TLIF influence the operated vertebral segment lordosis. Cages with lordotic angulation can maintain or restore lordosis due to its geometric shape.⁷ Cages that lack angulation also influence the vertebral segment lordosis depending on their position on the vertebra body surface (anterior, medial or posterior).⁸⁻¹⁰

All authors declare no potential conflict of interest related to this article.

Correspondence: Thiago Dantas Matos. Avenida Bandeirantes 3900, Monte Alegre 14049900- Ribeirão Preto, SP, Brazil, 14049-900. tdmatos@usp.br



Although Cage positioning in the vertebral segment lordosis is recognizably important^{11,12}, there is no consensus on the spacer proper positioning on the body surface. According to Kwon et al.¹³, a spacer should be used in the anterior part of the vertebral endplate, achieving greater segment stability and increasing the lordosis of the vertebral segment operated. However, Faundez et al.⁸ found that the spacer positioning did not cause a difference in lumbar lordosis, result corroborated by Ould-Slimane et al.¹⁰ Cage positioning also influences intervertebral foramen.⁹ The contralateral foramen stenosis after performing open TLIF has been related to segmental lordosis hypercorrection.^{14,15} The incidence of contralateral radiculopathy, secondary to the reduction of vertebral foramen dimensions after TLIF, is 5.9%.¹⁴ Contralateral radiculopathy after TLIF has been reported after the open or percutaneous approach.¹⁴⁻¹⁶ The precise compression mechanism of contralateral vertebral foramen is not completely clear and might be related to increased segmental lordosis during surgery.^{9,14} However, indirect decompression by increasing the intervertebral foramen height can be obtained by restoring the intervertebral disc height using Cage.⁹ Although clinical reports describe morphological changes in lumbar intervertebral foramina and the influence of the spacers position on the segmental lordosis after TLIF^{9,11,12}, literature lacks reports of bench tests on the influence of vertebral spacers on the height of the intervertebral foramen and on lordosis of the vertebral segment operated. This study aimed to evaluate height change of intervertebral foramen and of segmental lordosis related to Cage positioning after transforaminal lumbar interbody fusion (TLIF).

METHODS

In the study, an anatomical model of lumbar spine with vertebrae made with solid foam of low-density polyurethane and polyethylene intervertebral disc (Nacional Ossos[®]) was used. Experiments used PEEK (polyether ether ketone) spacers Fusimax TLP[®] model (Vincula, Brazil), 8 mm wide, 29 mm long, 8 mm, 10 mm, 12 mm and 14 mm high, and non-angulated, used for transforaminal lumbar interbody fusion (TLIF) (Figure 1).



Figure 1. Photo of Cage in height ascending order (8 mm, 10 mm, 12 mm and 14 mm)

The experimental model consisted in removing the intervertebral disc, performing bilateral cataract surgery, positioning the intervertebral spacer, applying compression in the vertebral segment, and bilaterally measuring lordosis and craniocaudal diameter of the intervertebral foramen. Spacers 8 mm, 10 mm, 12 mm and 14 mm high were inserted in all disc spaces, except for L1-L2, which could not use the 14 mm spacer because of their height. The study variables were: the positioning of intervertebral spacers (at the posterior, medial or anterior part of the vertebral body upper surface) (Figure 2), and the intervertebral spacers height (8 mm, 10 mm, 12 mm and 14 mm) (Figure 1). Compression of the vertebral segment was performed with compression clamps, and the compression limit was the bone contact of the posterior elements, which was a mechanical obstacle to additionally apply compression in the vertebral segment.

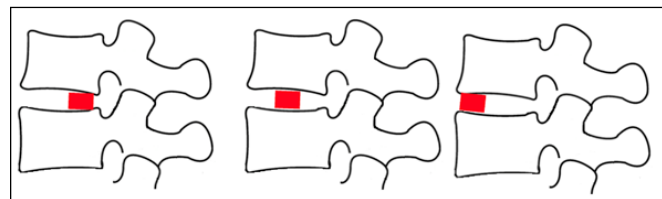

Figure 2. Illustration of the spacer positioning on the vertebral body upper surface (posterior, medial and anterior).

The vertebral segment lordosis was evaluated by measuring the angle formed by the threaded Steinmann pins put inside the vertebral pedicles. The angle was measured before removing the intervertebral disc and after placing the intervertebral spacer and applying compression in the vertebral segment (Figure 3). The craniocaudal diameter of the intervertebral foramen was evaluated by direct measurement with caliper, defined as foramen height. It was bilaterally measured before removing the intervertebral disc and after placing the spacer and applying compression in the vertebral segment. This study was not submitted to the Ethics and Research Committee as it is an experimental study that did not involve human beings at any stage of its realization. For this reason, the Term of Free and Informed Consent was not applied.

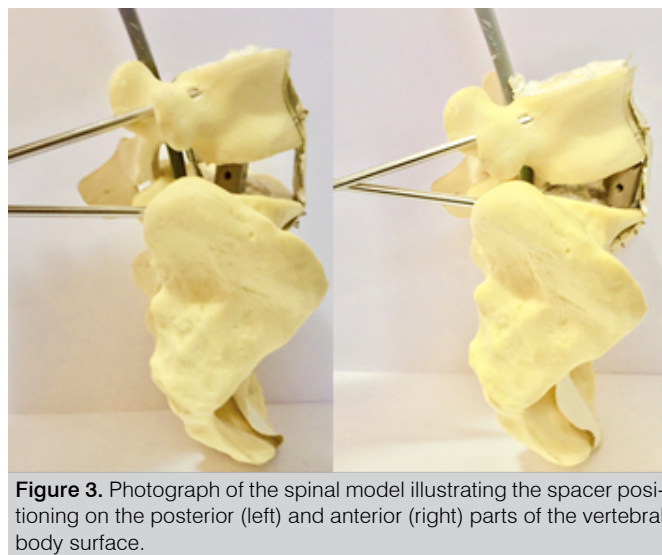

Figure 3. Photograph of the spinal model illustrating the spacer positioning on the posterior (left) and anterior (right) parts of the vertebral body surface.

STATISTICAL ANALYSIS

Statistical analysis was performed using the Kolmogorov-Smirnov test to determine the normality of each group sample. Mood's median test, a nonparametric test, was used to evaluate the influence of intervertebral spacers positioning and height on the intervertebral segment lordosis and intervertebral foramen height, with significance level $p < 0.05$. SAS Institute Inc., SAS/STAT[®] User's Guide, Version 9.4, Cary, NC: SAS Institute Inc., 2012 was used to perform statistical analysis.

RESULTS

The intervertebral foramen height reduced in relation to the values of the control group in all the tests (Mood's test $p < 0.05$). The intervertebral foramen height reduced regardless of the spacers position and height on the vertebra surface (Table 1 and Figure 4). The intervertebral foramen height tended to reduce as the spacer shifted to the anterior position of the vertebral body surface, but without statistical difference (Figures 4-5).

Table 1. Height values of the foramen and vertebral lordosis in the different experimental groups

Cage	Group	Foramen Height (mm)		Lordosis in Degrees	
		Mean (standard deviation)	Mean (standard deviation)	Mean (standard deviation)	Mean (standard deviation)
8	Anterior	11.70 1.75*	9.80 2.28		
	Medial	11.80 1.75*	11.80 2.49		
	Posterior	13.60 1.78*	13.40 4.88		
10	Anterior	12.88 2.17*	10.80 3.27		
	Medial	13.20 1.92*	13.00 5.39		
	Posterior	14.90 1.56*	13.60 5.41		
12	Anterior	13.50 2.12*	13.00 6.28		
	Medial	13.60 2.19*	15.00 6.48		
	Posterior	16.30 1.48*	16.20 6.87		
14	Anterior	15.25 2.90*	17.00 6.16		
	Medial	17.00 2.61*	17.75 7.68		
	Posterior	19.00 1.47*	18.75 7.63		

*: Statistical difference ($p < 0.05$) in relation to the control group.

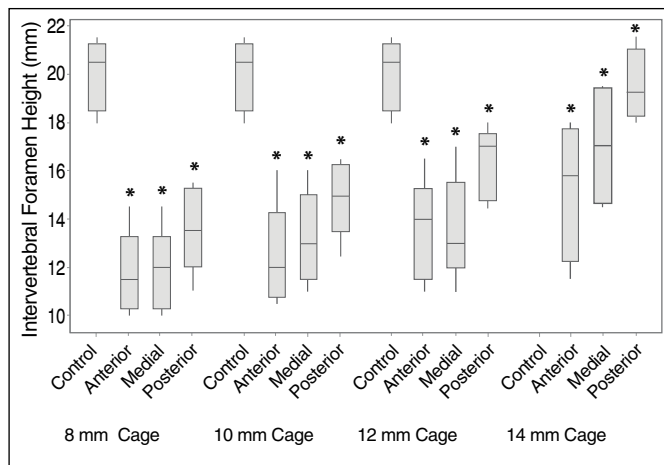

Figure 4. Height values of the vertebral foramen in the different spacers and positioning. Asterisk indicates statistical difference in relation to the control.

In the posterior positioning of the vertebral body surface, the 14 mm high spacer reduced less the intervertebral foramen height with statistical significance (Mood's test $p < 0.05$) when compared with the other spacers with smaller height in the same position.

The vertebral segment lordosis increased in relation to the control in all the variables (spacer positioning in relation to the body surface and spacer height). The spacer posterior positioning on the vertebral body surface and the use of a spacer with increased height tended to obtain higher values of the segment lordosis in which the TLIF was performed. (Table 1 and Figure 5)

The analysis of the results, considering only the use of the vertebral spacer of height close to the intervertebral disc height (spacer height 1 mm lower than disc height), is represented in Table 2.

The use of spacer of height close to the intervertebral disc height showed that the highest value of the vertebral segment lordosis was observed with the spacer posterior positioning. The spacer posterior positioning in this situation was the one that least reduced the intervertebral foramen height.

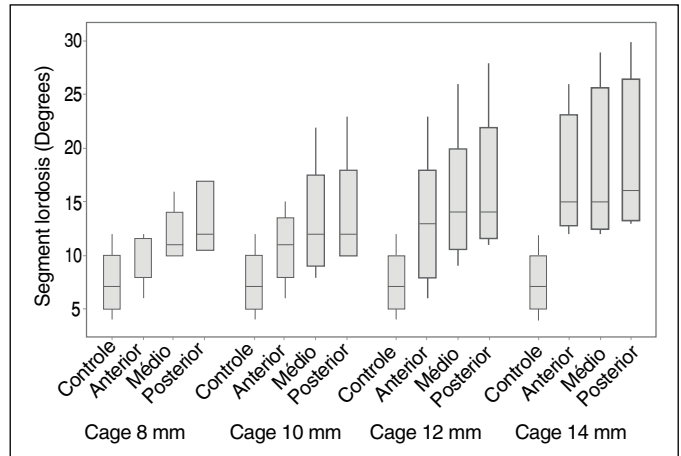

Figure 5. Segmental lordosis values with the use of the different spacers in the different positions.

Table 2. Height values of intervertebral foramen and of segmental lordosis with the use of the vertebral spacer at height close to the intervertebral disc height.

Segment	DH	SH	Foramen Height (mm)			Lordosis in Degrees				
			Post.	Med.	Ant.	Cont.	Post.	Med.	Ant.	Cont.
L1/L2	13	12	17	13	14	18	11	9	6	4
L2/L3	15	14	19	15	17	20.5	13	12	12	6
L3/L4	15	14	18	14.5	14.5	21	16	14	15	8
L4/L5	15	14	19.5	19.5	18	21.5	16	16	15	7
L5/S1	15	14	21.5	19	11.5	19	30	29	26	12

DH: Disc height; SH: Spacer height (mm); Post.: Posterior; Med.: Medial; Ant.: Anterior; Cont.: Control.

The experiment results were validated using trigonometric principles, in which the highest angular value of the vertebral segment was observed with the spacers posterior positioning (Figure 6). We considered "A" as the height of the anterior spacer, "P" the height of the posterior spacer, "d" the distance from the posterior edge of the vertebral body (in the media line) to the posterior edge of the spacer (in the media line), and angle "L" as angle of the segmental lordosis presented. Thus, the formula $A = P + (d \times \sin L)$ allows to demonstrate that the same degree of segmental lordosis was obtained with spacers of different heights positioned in the anterior or posterior part of the vertebral body. For example, the 11.22 mm high anterior spacer and the 8 mm high posterior spacer would produce the same segmental lordosis.

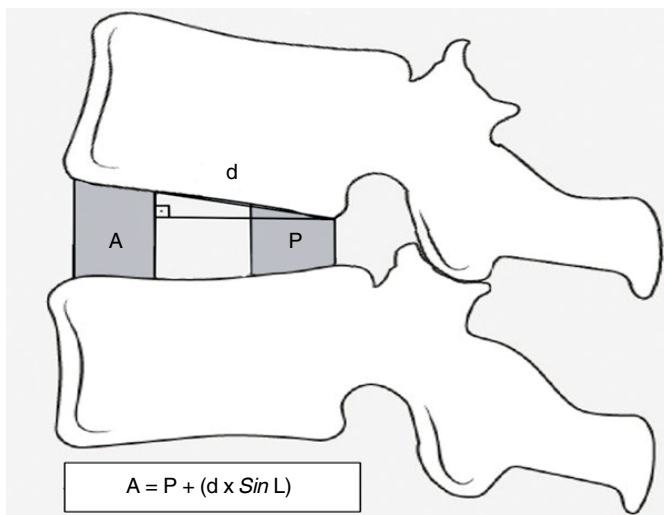

Figure 6. Formula illustration. A: Anterior Cage; P: Posterior Cage; D: Distance from the posterior limit of the posterior cage to the posterior limit of the anterior cage; L: Segment lordosis angle; Sin: Sine.

DISCUSSION

The position of kidney-type spacers in TLIF procedures induces morphological changes in intervertebral foramen and in the lordosis of the operated segment. Contralateral radiculopathy after TLIF is reported ranging from 2% to 8.5% after TLIF-MIS^{16,17} and 1.9% to 5.9% after open TLIF^{14,16} and drew attention to changes in intervertebral foramen after this procedure. Contralateral foraminal stenosis is the most frequent cause of contralateral radiculopathy after the use of a unilateral TLIF. Other factors such as poor screw positioning, disc herniation and hematoma were also reported.¹⁴ In our study, intervertebral foramen height reduction with statistical significance was observed in all the spacers. However, it should be considered that most of the spacers was smaller than the control disc. The original disc height could not be restored with smaller spacers, but the spacers positioning influenced the reduction of the intervertebral foramen height (Table 2). The spacer posterior positioning induced the lower reduction in the intervertebral foramen height in different sizes of spacers. Iwata et al.⁹ also found this result and showed a significant increase in the foramen height with the posterior positioning. The analysis of the results considering only the values corresponding to the spacer height according to the control disc height also showed a tendency of more correction of the segmental lordosis and less reduction in the intervertebral foramen height. The use of the spacer with height close to the intervertebral disc height is similar to the clinical use of spacers, which avoids spacers with superior or inferior height than the intervertebral disc height. Although no statistical difference was seen between the spacer positions on the intervertebral foramen height, the observed tendency is for its lower reduction with posterior positioning. The lower reduction in the intervertebral foramen height with posterior positioning is clinically relevant, because contralateral

radiculopathy can be a result of failure to obtain indirect decompression.¹⁴⁻¹⁶ According to our findings, restoring the disc height should be enough to allow the contralateral foramen indirect decompression with the appropriate spacer height and its posterior position. Contralateral foramen indirect decompression in TLIF depends on the spacer height and position.

Originally, the TLIF technique was described to use two titanium spacers in the mid or posterior third of the intervertebral space and fill with bone graft anteriorly behind the anterior longitudinal ligament. Spacers must provide initial distraction and segmental stability, as well as the support of axial loads.¹ Biomechanics studies suggested anteriorly positioning spacers would result in better load sharing and increase stability.^{8,18} Although spacers anterior positioning can improve the instrumentation stiffness of the vertebral segment, it reduces the intervertebral foramen height, causing contralateral intervertebral foramen stenosis. *In vitro* mechanical studies presented a different conclusion, recommending the posterolateral positioning of spacers used in the TLIF to obtain better mechanical stability and high fusion consolidation rates.¹⁹

The ideal alignment of the lumbar spine sagittal plane is still unknown. However, the positive correlation between reconstruction or maintenance of lumbar lordosis and clinical outcomes has been widely reported.^{5,20} To avoid “flatback syndrome”, segmental lordoses must be maintained or reconstructed.

The increase in lordosis in relation to control values occurred with the use of spacers of different heights, as well as in their location. Spacers located in the posterior position on the vertebral endplate tended to obtain greater lordosis. Production of segmental lordosis is associated with decreased intervertebral foramen height. A negative correlation is visible between increased segmental lordotic angle and changes in foraminal morphology and in transverse area of intervertebral foramen.⁹ The increase in lordosis during TLIF may affect the contralateral foramen.^{9,16} The segmental lordotic angle is significantly higher in symptomatic patients with contralateral radiculopathy when compared with asymptomatic patients.¹⁶

The analysis of the results must consider that the model has different characteristics from those biological and biomechanical lumbar spine characteristics. Ligaments and other structures, part of the lumbar spine biomechanical properties, are absent in the artificial model. The results reflect only the geometric changes in the model after inserting the Cage in the different positions. However, they open the perspective for a critical analysis of changes induced by intervertebral spacers, as well as the motivation to study these changes using human vertebrae for more accurate observation of changes induced by vertebral spacers.

The spacer must be able to restore the intervertebral disc height and maintain or restore the segmental lordosis. According to the results of our study, spacers should be placed in the posterior part of the spine to reach the objectives.

CONCLUSIONS

The results indicate that the posterior positioning of the vertebral spacer induces a lower reduction in the intervertebral foramen height and increased vertebral segment lordosis.





AUTHORS' CONTRIBUTION: Each author contributed individually and significantly to the development of this article. TDM: substantial contributions to the study conception; data acquisition and interpretation. Final approval of the manuscript version to be published; RBCF: contribution to data collection and analysis; KOT: contribution to data collection and analysis; VR: article review and intellectual analysis; HLAD: final approval of the manuscript version to be published and contributions to the analysis and interpretation of the study data.

REFERENCES

1. Harms JG, Jeszenszky D. Die posteriore, lumbale, interkorporelle Fusion in unilateraler transforaminaler Technik. *Operat Orthop Traumatol*. 1998;10(2):90-101.
2. Rickert M, Rauschmann M, Fleege C, Behrbalk E, Harms J. [Interbody Fusion Procedures. Development From a Historical Perspective]. *Orthopade*. 2015;44(2):104-13. German.
3. Cheng X, Zhang F, Zhang K, Sun X, Zhao C, Li H, et al. Effect of Single-Level Transforaminal Lumbar Interbody Fusion on Segmental and Overall Lumbar Lordosis in Patients with Lumbar Degenerative Disease. *World Neurosurg*. 2018;(109):e244-e51.
4. Booth KC, Bridwell KH, Lenke LG, Baldus CR, Blanke KM. Complications and Predictive Factors for the Successful Treatment of Flatback Deformity (Fixed Sagittal Imbalance). *Spine (Phila Pa 1976)*. 1999;24(16):1712-20.
5. Lazennec JY, Ramaré S, Arafati N, Laudet CG, Gorin M, Roger B, et al. Sagittal Alignment in Lumbosacral Fusion: Relations between radiological parameters and pain. *Eur Spine J*. 2000;9(1):47-55.
6. Kim MK, Lee SH, Kim ES, Eoh W, Chung SS, Lee CS. The Impact of Sagittal Balance on Clinical Results After Posterior Interbody Fusion for Patients With Degenerative Spondylolisthesis: a pilot study. *BMC Musculoskelet Disord*. 2011;12:69.
7. Gödde S, Fritsch E, Dienst M, Kohn D. Influence of Cage Geometry on Sagittal Alignment in Instrumented Posterior Lumbar Interbody Fusion. *Spine (Phila Pa 1976)*. 2003;28(15):1693-9.
8. Faundez AA, Mehbod AA, Wu C, Wu W, Ploumis A, Transfeldt EE. Position of Interbody Spacer in Transforaminal Lumbar Interbody Fusion: Effect on 3-dimensional stability and sagittal lumbar contour. *J Spinal Disord Tech*. 2008;21(3):175-80.
9. Iwata T, Miyamoto K, Hioki A, Fushimi K, Ohno T, Shimizu K. Morphologic Changes in Contralateral Lumbar Foramen in Unilateral Cantilever Transforaminal Lumbar Interbody Fusion Using Kidney-type Intervertebral Spacers. *J Spinal Disord Tech*. 2015;28(5):E270-6.
10. Ould-Slimane M, Lenoir T, Dazuc C, Rillardon L, Hoffmann E, Guigui P, Ilharberorde B. Influence of Transforaminal Lumbar Interbody Fusion Procedures on Spinal and Pelvic Parameters of Sagittal Balance. *European Spine Journal*. 2011;(6):1200-6.
11. Wang SJ, Han YC, Pan FM, Ma B, Tan J. Single Transverse-Orientation Cage via MIS-TLIF Approach for the Treatment of Degenerative Lumbar Disease: a technical note. *Int J Clin Exp Med*. 2015;8(8):14154-60.
12. Kepler CK, Rihn JA, Radcliff KE, Patel AA, Anderson DG, Vaccaro AR, et al. Restoration of Lordosis and Disk Height After Single-Level Transforaminal Lumbar Interbody Fusion. *Orthop Surg*. 2012;4(1):15-20.
13. Kwon BK, Berta S, Daffner SD, Vaccaro AR, Hillibrand AS, Grauer JN, et al. Radiographic Analysis of Transforaminal Lumbar Interbody Fusion for the Treatment of Adult Isthmic Spondylolisthesis. *J Spinal Disord Tech*. 2003;16(5):469-76.
14. Jang KM, Park SW, Kim YB, Park YS, Nam TK, Lee YS. Acute Contralateral Radiculopathy After Unilateral Transforaminal Lumbar Interbody Fusion. *J Korean Neurosurg Soc*. 2015;58(4):350-6.
15. Hunt T, Shen FH, Shaffrey CI, Arlet V. Contralateral Radiculopathy After Transforaminal Lumbar Interbody Fusion. *Eur Spine J*. 2007;16(Suppl 3):311-4.
16. Yang Y, Liu ZY, Zhang LM, Dong JW, Xie PG, Chen RQ, et al. Risk Factor of Contralateral Radiculopathy Following Microendoscopy-Assisted Minimally Invasive Transforaminal Lumbar Interbody Fusion. *Eur Spine J*. 2017;(8):1925-32.
17. Schwender JD, Holly LT, Rouben DP, Foley KT. Minimally Invasive Transforaminal Lumbar Interbody Fusion (TLIF): Technical feasibility and initial results. *J Spinal Disord Tech*. 2005;18 (Suppl):S1-6.
18. Polly DW Jr, Klemme WR, Cunningham BW, Burnette JB, Haggerty CJ, Oda I. The Biomechanical Significance of Anterior Column Support in a Simulated Single-Level Spinal Fusion. *J Spinal Disord*. 2000;13(1):58-62.
19. Lowe TG, Hashim S, Wilson LA, O'Brien MF, Smith DA, Diekmann MJ, Trommeter J. A Biomechanical Study of Regional Endplate Strength and Cage Morphology as it Relates to Structural Interbody Support. *Spine (Phila Pa 1976)*. 2004;29(21):2389-94.
20. Kim JT, Shin MH, Lee HJ, Choi DY. Restoration of Lumbopelvic Sagittal Alignment and its Maintenance Following Transforaminal Lumbar Interbody Fusion (TLIF): Comparison between straight type versus curvilinear type cage. *Eur Spine J*. 2015;24(11):2588-96.

EPIDEMIOLOGICAL PROFILE OF MOTORCYCLE ACCIDENT VICTIMS IN UNIVERSITY HOSPITAL

PERFIL EPIDEMIOLÓGICO DE VÍTIMAS DE ACIDENTES DE MOTO EM HOSPITAL UNIVERSITÁRIO

CINTIA KELLY BITTAR¹ , ALBERTO CLIQUET JÚNIOR² , VINÍCIUS SAMUEL DIAS ALVES DA COSTA³ , ANA CAROLINA DE FREITAS PACHECO³ , RENATO LAZARIN RICCI³ 

1. Pontifícia Universidade Católica de Campinas, Hospital Celso Pierro, Campinas, SP, Brazil.

2. Universidade Estadual de Campinas, School of Medical Sciences, Department of Orthopedics and Traumatology, Campinas, SP, Brazil.

3. Pontifícia Universidade Católica de Campinas, School of Medical Sciences, Campinas, SP, Brazil.

ABSTRACT

Objective: To evaluate the epidemiological profile of motorcycle accident victims in a metropolis with more than one million inhabitants attended in a university hospital of reference in 2017. **Methods:** a retrospective study through the analysis of medical records of 105 motorcycle accident victims in Campinas (SP) attended in a university hospital of reference and who needed surgical procedure in 2017. **Results:** 87 patients (82.9%) were men. Multiple fractures were observed in 61 patients (58.1%) and polytrauma was found in 14 patients (13.3%). Tibial fracture was the most frequent, present in 65 cases (61.9%). Exposed fractures occurred in 68 patients (64.7%). Among the polytrauma victims, the most frequent injury was traumatic brain injury (TBI), present in seven patients (6.6%). The mean age was 29.8 years (range 6-63 years). The average length of hospital stay was 14 days (1-87). **Conclusion:** It is essential to investigate and evaluate the victims' epidemiological profile, as well as the resulting injuries, in order to provide adequate support for the implementation of measures aimed at primary prevention and awareness of the most affected groups. **Level of Evidence II, Prognostic studies – Investigating the effect of a patient characteristic on the outcome of disease.**

Keywords: Accidents, Traffic. Health Profile. Multiple Trauma. Craniocerebral Trauma.

RESUMO

Objetivo: Avaliar o perfil epidemiológico das vítimas de acidentes motociclísticos ocorridos em uma metrópole com mais de 1 milhão de habitantes atendidas em um hospital universitário de referência no ano de 2017. **Métodos:** Estudo retrospectivo através da análise de prontuários de 105 vítimas de acidentes motociclísticos ocorridos em Campinas, SP, Brasil, no ano de 2017 atendidas em um hospital universitário de referência que necessitaram de procedimento cirúrgico. **Resultados:** Oitenta e sete pacientes (82,9%) eram do sexo masculino. Foram verificadas polifrações em 61 pacientes (58,1%) e politraumatismo em quatorze (13,3%). A fratura de tíbia foi a mais frequente, presente em 65 casos (61,9%). Fraturas expostas ocorreram em 68 pacientes (64,7%). Entre as vítimas de politraumatismo, a lesão mais recorrente foi o traumatismo cranioencefálico (TCE), presente em sete pacientes (6,6%). A média de idade foi 29,8 anos (variando de 6-63 anos). O tempo de internação médio foi 14 dias (1-87). **Conclusão:** É fundamental investigar e avaliar o perfil epidemiológico das vítimas, assim como os agravos resultantes, de modo a propiciar subsídio adequado para implementação de medidas de prevenção primária e conscientização, especialmente direcionadas para os grupos mais acometidos. **Nível de Evidência II, Estudos prognósticos – Investigação do efeito de característica de um paciente sobre o desfecho da doença.**

Descritores: Acidentes de Trânsito. Perfil de Saúde. Traumatismo Múltiplo. Traumatismos Craniocerebrais.

Citation: Bittar CK, Cliquet A Jr, Costa VSDA, Pacheco ACF, Ricci RL. Epidemiological profile of motorcycle accident victims in university hospital. *Acta Ortop Bras.* [online]. 2020;28(2):97-9. Available from URL: <http://www.scielo.br/aob>.

INTRODUCTION

Traffic accidents are considered a major problem for public health in the world, being one of the main causes of morbidity and mortality. According to the World Health Organization (WHO), about 1.2 million people die each year from traffic accidents worldwide, of which

90% are concentrated in low- or medium-development countries.¹ In Brazil, it is estimated more than 980,000 deaths following traffic trauma between 1980 and 2011.² From 1998 to 2010, the motorcycle fleet growth in Brazil was 490%, jumping from 2,800,000 to 16,500,000, supported by government

All authors declare no potential conflict of interest related to this article.

The study conducted at the Pontifícia Universidade Católica de Campinas, Centro de Ciências da Vida, Faculdade de Medicina, Campus II. Correspondence: Vinicius Samuel Dias Alves da Costa. Av. John Boyd Dunlop, S/N, Campinas, SP, Brazil, 13060-904. viniciusssamuel@gmail.com



policies that stimulated manufacturing, reduced the cost, and enabled the financing of these vehicles. It is important to highlight that, in the same period, the automobiles general fleet growth was 160%, which indicates a growth three times higher in the number of motorcycles.¹

Motorcyclists are one of the most susceptible and likely groups to engage in traffic accidents. When compared with other means of locomotion, having a motorcycle has its benefits, such as easy travel capacity on congested roads, low purchase price and maintenance cost, and fuel economy, in addition to its increasing use in the labor market (motorcycle taxi and deliveries). Therefore, the motorcycle use in Brazil has been increasing significantly.^{1,3}

Associated with this significant increase in motorcycles in circulation, the mortality involving motorcyclists in Brazil grew by 700% from 1998 to 2008, thus being responsible for a substantial increase in the number of hospitalizations in public services. In 2000, 16,692 hospitalizations were recorded. In 2005, this number grew to 30,562 (83%).³ Thus, the need for new public policies in order to reduce traffic accidents is evident.

Regarding the epidemiological profile of motorcycle accidents, many studies indicate the young male population is the most vulnerable, and head and lower limb injuries are the most prevalent. In addition, obese motorcyclists have longer length of hospital stay and different body injuries when compared with normal weight motorcyclists.⁴⁻⁶ Thus, safety measures, such as the use of appropriate helmets and clothing are extremely important for injury protection, reduced length of hospital stay, prevention of physical disability, and for the economy of social costs, reducing the need for institutional care.^{7,8} Therefore, in order to reduce the number of victims involved in motorcycle accidents, traffic accidents should be treated as a health promotion issue, with the development of intersectoral projects to stimulate the participation of the entire population and the adoption of more supportive behaviors, which aim both at traffic education and information on the physical consequences of motorcycle accidents.⁹ Furthermore, improving the infrastructure of streets and roads is crucial for the proper movement of motor vehicles. This study aims to evaluate the epidemiological profile of motorcycle accident victims that occurred in a metropolis with more than one million inhabitants attended in a university hospital of reference in 2017.

METHODS

This is a retrospective cross-sectional study conducted at the PUC-Campinas Hospital, filed by the Research Ethics Committee with registration on *Plataforma Brasil* under the number 88812818.3.0000.5481, in which the analysis of medical records of 105 patients, who were motorcycle accident victims in Campinas, São Paulo, Brazil, were performed in 2017 (from January to December 2017). The patients were treated primarily in the emergency room of a university hospital of reference and required surgical procedure.

The following characteristics were evaluated: sex, age, length of hospital stay, type and frequency of injuries (fractures, multiple fractures, and polytraumas), and infection occurrence.

Data were analyzed from medical records listed in the Orthopedics and Traumatology service of the PUC-Campinas Hospital. All study participants signed an informed consent form.

RESULTS

Among the 105 analyzed patients, 87 (82.9%) were men and 18 (17.1%) were women. The mean age was 29.8 years (range 6-63 years). Among all victims, 61 (58.1%) had multiple fractures and 14 (13.3%) presented polytrauma. Tibia fracture was the most common,

present in 65 cases (61.9%), followed by femur and fibula fractures, with 30 cases each (28.5%), and radio and humerus fracture, with six cases (11.4%). Exposed fractures occurred in 68 patients (64.7%). Among the polytrauma victims, the most frequent injury was traumatic brain injury (TBI), present in seven patients (6.6%); followed by pulmonary injuries, with six cases (5.7%); urinary tract injury, with four cases (3.8%); and liver, splenic, and testicular injuries, with one case each (1%). Besides, among the polytraumatized patients, 12 of them (11.4%) also suffered multiple fractures. Infections were observed in 49 patients (46.6%). The mean length of hospital stay was 14 days, with a minimum stay of one day and a maximum of 87 days.

DISCUSSION

Data from the literature indicate a predominance of motorcycle accidents involving men, ranging from 79% to 96%.¹⁰ This study confirmed these data, with a prevalence of 82.9% male patients. The greater involvement of male motorcyclists is related to risky driving behavior and disrespect for the traffic laws, since data indicate most accidents occur due to motorcyclists' carelessness.^{10,11} Regarding the age group, 63.8% of the patients were aged between 11 and 35 years. In a study conducted in Piauí, 74.4% of those injured were aged 10 to 39 years.¹¹ Other studies indicate that the predominant victims involved in fatal motorcycle accidents are young people from the age group of 15 to 29 years.⁴

The higher occurrence of accidents among young people and adolescents is related to relevant socioeconomic factors. First, motorcycles represent an alternative of lower cost, greater agility, and independence for young people when compared with public transportation.⁴ Associated with this, young people generally present risky driving behavior and have less experience and driving skills.¹⁰ Another relevant point in this study is the presence of underage individuals involved in motorcycle accidents. There were 10 victims aged between 14 and 17 years, and the minimum age determined by Brazilian legislation for drivers' qualification is 18 years old. Data on the position of the victims regarding the accident (driver or passenger) were not collected, but it is believed that among those patients mentioned above, not all were passengers. This fact shows the need for better investigation regarding motorcycle riding by unqualified individuals and its impact on traffic accidents. In a study conducted in the municipality of Campinas,⁴ we found that the number of traffic accidents with victims increased after 2004, mainly due to the significant motorcycle fleet growth. Likewise, a mortality growth involving motorcyclists was also observed.

Regarding the injuries found, the most frequent ones were those of the lower limbs, mainly represented by tibia fractures, which were observed in 65 patients (61.9%). Koizumi found that the lower limbs are the most affected in motorcycle accidents, representing about 29.8% of them, followed by head injuries (21.5%).¹² The highest incidence of injuries in the lower limbs is directly related to lower protection and greater exposure of these body areas in motorcyclists as opposed to the head, which is protected by helmet.¹³ However, Koizumi points out that the frequency of injuries by body region changes in patients who died, being more observed in patients who suffered head lesions, followed by abdominal, lower limb, and pelvic lesions.¹²

It is noteworthy that no data were collected regarding patients who died. However, we observed that seven patients (6.6%) were victims of TBI, which is among the most frequent fatal injuries, with high severity, in addition to a high degree of disability.^{10,12,14} The importance of wearing helmets for TBI prevention stands out, with studies showing the significantly higher occurrence of this condition in individuals who do not use any safety equipment.¹²

In this study, multiple fractures occurred in 61 (58.1%) victims. These data directly focused on the length of hospital stay, on average 14 days, with a minimum of one day and a maximum of 87 days, since orthopedic patients are among those who contribute the most to increasing the length of hospital stay. Koizumi established 15.8 days of average hospitalization.¹² Long length of hospital stay is directly associated with greater trauma severity and with the occurrence of infectious complications. In this study, 49 patients (46.6%) presented infection during the hospitalization. Araújo and Whitaker point out that patients who suffered motorcycle accidents and evolved with complications have longer hospitalization time, mainly because of infectious situations, such as surgical site infection, and pressure ulcer.¹⁵

This study has a limitation regarding the methodology applied, as it was a retrospective analysis, dependent on medical records

information. Therefore, it was impossible to confirm any information not completed in the patient records.

The identification of the epidemiological profile of patients involved in motorcycle accidents and the development of preventive measures are of outstanding importance, given the seriousness of the resulting injuries, with high morbidity and mortality, and the demand to health services.

CONCLUSIONS

Given the significant motorcycle fleet growth, the high incidence of traffic accidents involving these vehicles, especially among young male individuals, and the resulting high morbidity and mortality rates, it is essential to investigate and evaluate the victims' epidemiological profile, as well as their resulting injuries, in order to provide adequate support for the implementation of measures aimed at primary prevention and awareness of the most affected group.

AUTHORS' CONTRIBUTION: Each author contributed individually and significantly to the development of this article. CKB: study design, review, and approval of the final version; ACJ: study design, review, and approval of the final version; VSDAC: data collection, analysis and interpretation, and writing; ACFP: data collection, analysis and interpretation; RLR: data collection, analysis and interpretation.

REFERENCES

1. Martins ET, Boing AF, Peres MA. Motorcycle accident mortality time trends in Brazil, 1996-2009. *Rev Saude Publica.* 2013;47(5):1-11.
2. Oliveira AL, Petroianu A, Gonçalves DMV, Pereira GA, Alberti LR. Characteristics of motorcyclists involved in accidents between motorcycles and automobiles. *Rev Assoc Med Bras.* 2015;61(1):61-4.
3. Sant'Anna FL, de Andrade SM, Sant'Anna FHM, Liberatti CLB. Motorcycle accidents: comparison between the years 1998 and 2010 in Londrina, Southern Brazil. *Rev Saude Publica.* 2013;47(3):1-8.
4. Marín-León L, Belon AP, Barros MBA, Almeida SDM, Restitutti MC. [Trends in traffic accidents in Campinas, São Paulo State, Brazil: the increasing involvement of motorcyclists]. *Cad Saude Publica.* 2012;28(1):39-51. Portuguese.
5. Chichom-Mefire A, Atashili J, Tsiagadigui JG, Fon-Awah C, Ngowe-Ngowe M. A prospective pilot cohort analysis of crash characteristics and pattern of injuries in riders and pillion passengers involved in motorcycle crashes in an urban area in Cameroon: lessons for prevention. *BMC Public Health.* 2015;15:915.
6. Liu HT, Rau CS, Wu SC, Chen YC, Hsu SY, Hsieh HY, et al. Obese motorcycle riders have a different injury pattern and longer hospital length of stay than the normal-weight patients. *Scand J Trauma Resusc Emerg Med.* 2016;24:50.
7. Philip AF, Fangman W, Liao J, Lillienthal M, Choi K. Helmets prevent motorcycle injuries with significant economic benefits. *Traffic Inj Prev.* 2013;14(5):496-500.
8. de Rome L, Ivers R, Fitzharris M, Haworth N, Heritier S, Richardson D. Effectiveness of motorcycle protective clothing: riders' health outcomes in the six months following a crash. *Injury.* 2012;43(12):2035-45.
9. Brasil. Ministério da Saúde. Secretaria de Políticas de Saúde. Coordenação do projeto de Promoção da Saúde. Projeto de redução da morbimortalidade por acidente de trânsito: mobilizando a sociedade e promovendo a saúde. 2nd ed. Brasília, DF; 2002.
10. Dos Santos AMR, Moura MEB, Nunes BMVT, Leal CFS, Teles JBM. [Profile of motorcycle accident victims treated at a public hospital emergency department]. *Cad Saude Publica.* 2008;24(8):1927-38. Portuguese.
11. Andrade MA, Soares DA, Braga GP, Moreira JH, Botelho FMN. [Risky behavior for traffic accidents: a survey among medical students in Southern Brazil]. *Rev Assoc Med Bras.* 2003;49(4):439-44. Portuguese.
12. Koizumi MS. [Injury patterns in motorcycle accident victims]. *Rev Saude Publica.* 1992;26(5):306-15. Portuguese.
13. Oliveira NLB, de Sousa RMC. [Injury diagnosis quality of life among motorcyclists, victims of traffic accidents]. *Rev Lat Am Enfermagem.* 2003;11(6):749-56. Portuguese.
14. Batista SEA, Baccani JG, Silva RAP, Gualda KPF, Vianna Jr. RJA. [Mechanisms of trauma, main injuries and severity of patients' conditions in Catanduva – SP]. *Rev Col Bras Cir.* 2006;33(1):6-10. Portuguese.
15. Araujo GL, Whitaker IY. Hospital morbidity of injured motorcyclists: factors associated with length of stay. *Acta Paul Enferm.* 2016;29(2):178-84.